

BOM Table

ITEM NO.	PART NUMBER	Rev.	Description	Material	FlameRating	Color	QTY.
1	SN-21B-01	-	BASE	ABS	UL94-HB	BLACK	1
2	SN-22C-01	-	COVER	ABS	UL94-HB	BLACK	1

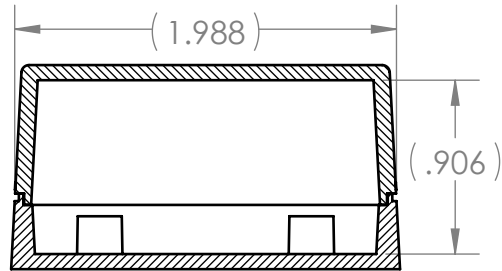
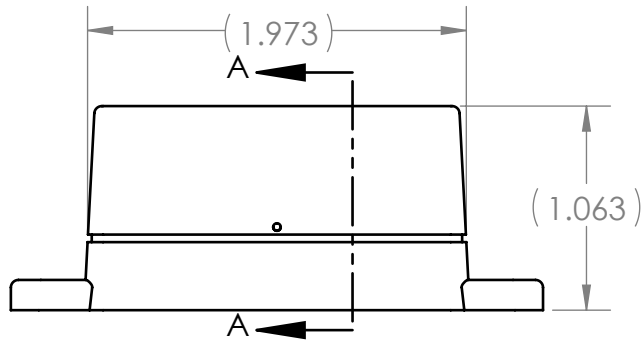
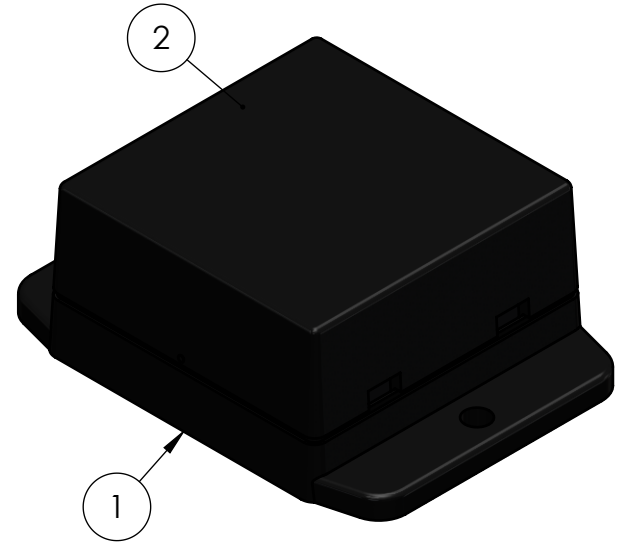
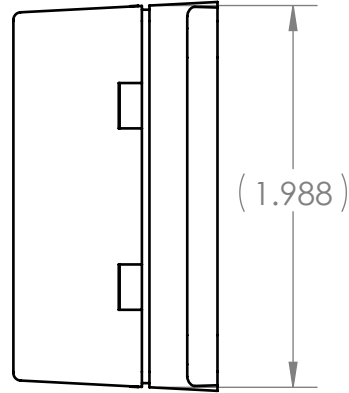
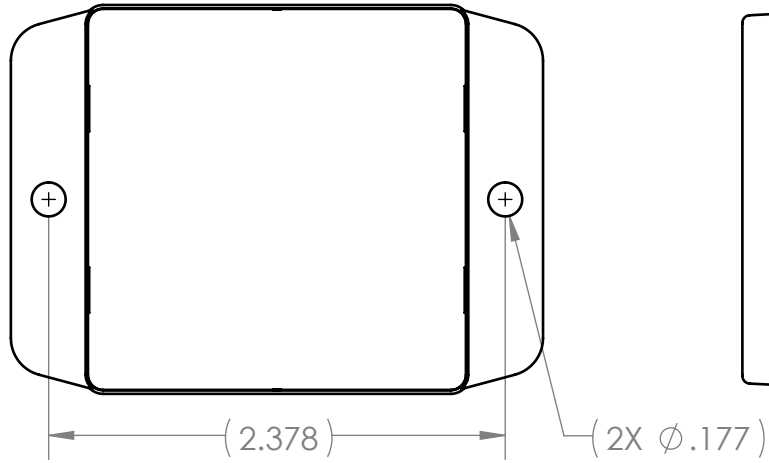

SECTION A-A

UNLESS OTHERWISE SPECIFIED:
 DIMENSIONS ARE IN: INCHES [mm]
 TOLERANCES: ANGULAR: ±°
 TWO PLACE DECIMAL: ±
 THREE PLACE DECIMAL: ±
 PRINTED GRAPHICS: ±.010

PROPRIETARY AND CONFIDENTIAL
 THE INFORMATION CONTAINED IN THIS
 DRAWING IS THE SOLE PROPERTY OF
 POLYCASE. ANY REPRODUCTION IN PART
 OR AS A WHOLE WITHOUT THE WRITTEN
 PERMISSION OF POLYCASE IS PROHIBITED.
 CAD FILE: SN-22

PART NO.
 SN-22-01
 MATERIAL

FLAME RATING

SIZE
A



1305 CHESTER IND. PARKWAY AVON, OHIO 44011-1083 U.S.A.
 PH# 1-800-248-1233, 440-934-0444 FAX# 440-934-0088

REV
 -

REV.	DESCRIPTION	ZONE	BY	APPR'D	DATE
REVISIONS					

	NAME	DATE
DRAWN	D.M.F.	6/25/2018
CHECKED	-	12/31/2999

SCALE: 1:1



SHEET 1 OF 1

5

4

3

2

1

D

C

B

A

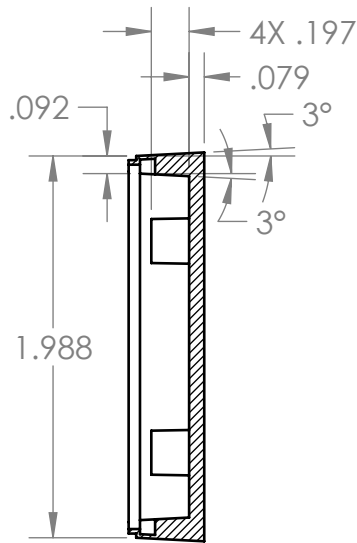
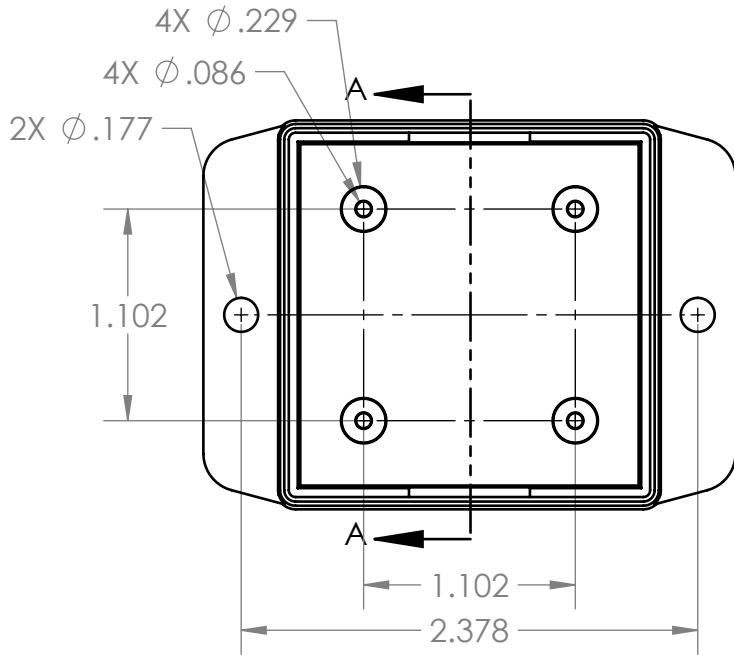
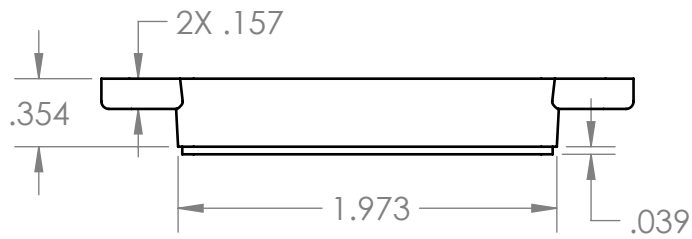

SECTION A-A

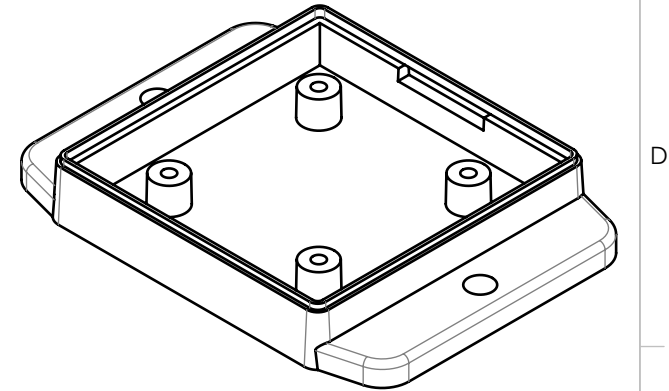

PART NUMBER: SN-21B-01
 MATERIAL: ABS
 COLOR: BLACK
 FLAME RATING: UL94-HB

UNLESS OTHERWISE SPECIFIED: DIMENSIONS ARE IN: INCHES [mm] TOLERANCES: ANGULAR: ±° TWO PLACE DECIMAL: ± THREE PLACE DECIMAL: ± PRINTED GRAPHICS: ±.010	PART NO. SN-21B-01		 <small>1305 CHESTER IND. PARKWAY AVON, OHIO 44011-1083 U.S.A. PH#: 1-800-248-1233, 440-934-0444 FAX#: 440-934-0088</small>
	MATERIAL ABS		
PROPRIETARY AND CONFIDENTIAL THE INFORMATION CONTAINED IN THIS DRAWING IS THE SOLE PROPERTY OF POLYCASE. ANY REPRODUCTION IN PART OR AS A WHOLE WITHOUT THE WRITTEN PERMISSION OF POLYCASE IS PROHIBITED. CAD FILE: SN-21B	FLAME RATING UL94-HB	SIZE A	BASE REV -
	DRAWN CHECKED	NAME D.M.F. -	DATE 6/25/2018 12/31/2999
SCALE: 1:1		SHEET 1 OF 1	

REV.	DESCRIPTION	ZONE	BY	APPR'D	DATE
REVISIONS					

5

4

3

2

1

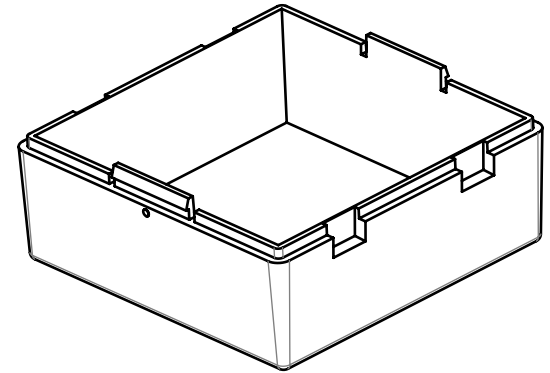
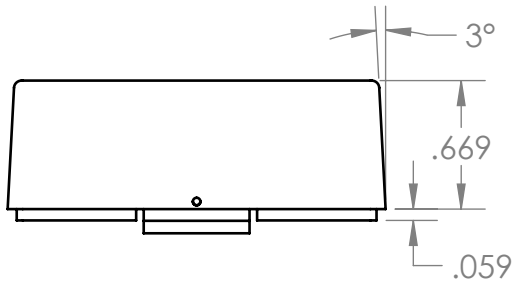

PART NUMBER: SN-22C-01
 MATERIAL: ABS
 COLOR: BLACK
 FLAME RATING: UL94-HB

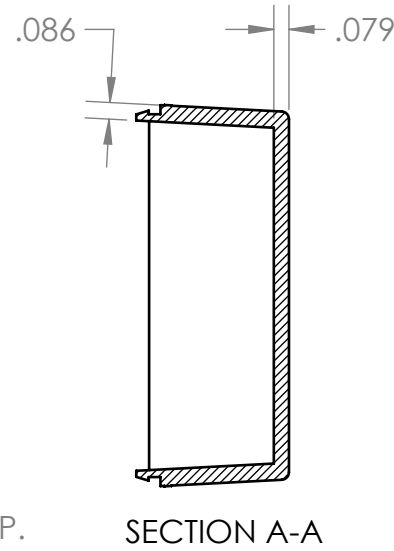
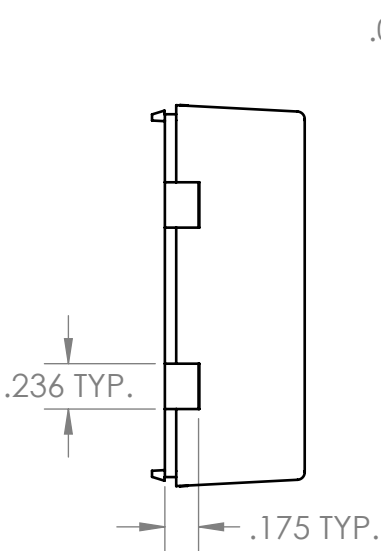
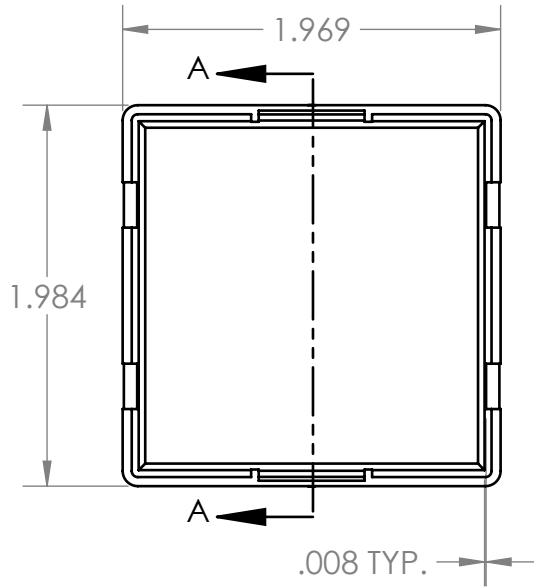

REV.	DESCRIPTION	ZONE	BY	APPR'D	DATE
REVISIONS					

UNLESS OTHERWISE SPECIFIED:
 DIMENSIONS ARE IN: INCHES [mm]
 TOLERANCES: ANGULAR: \pm .5°
 TWO PLACE DECIMAL: \pm .01
 THREE PLACE DECIMAL: \pm .005
 PRINTED GRAPHICS: \pm .010

PROPRIETARY AND CONFIDENTIAL
 THE INFORMATION CONTAINED IN THIS
 DRAWING IS THE SOLE PROPERTY OF
 POLYCASE. ANY REPRODUCTION IN PART
 OR AS A WHOLE WITHOUT THE WRITTEN
 PERMISSION OF POLYCASE IS PROHIBITED.
 CAD FILE: SN-22C

PART NO. SN-22C-01		SIZE A
MATERIAL ABS		
FLAME RATING UL94-HB		SCALE: 1:1
DRAWN	NAME	DATE
CHECKED	D.M.F.	6/25/2018
	-	12/31/2999

polycase
 1305 CHESTER IND. PARKWAY AVON, OHIO 44011-1083 U.S.A.
 PH#: 1-800-248-1233, 440-934-0444 FAX#: 440-934-0088

COVER	REV
	-

SHEET 1 OF 1

5

4

3

2

1