

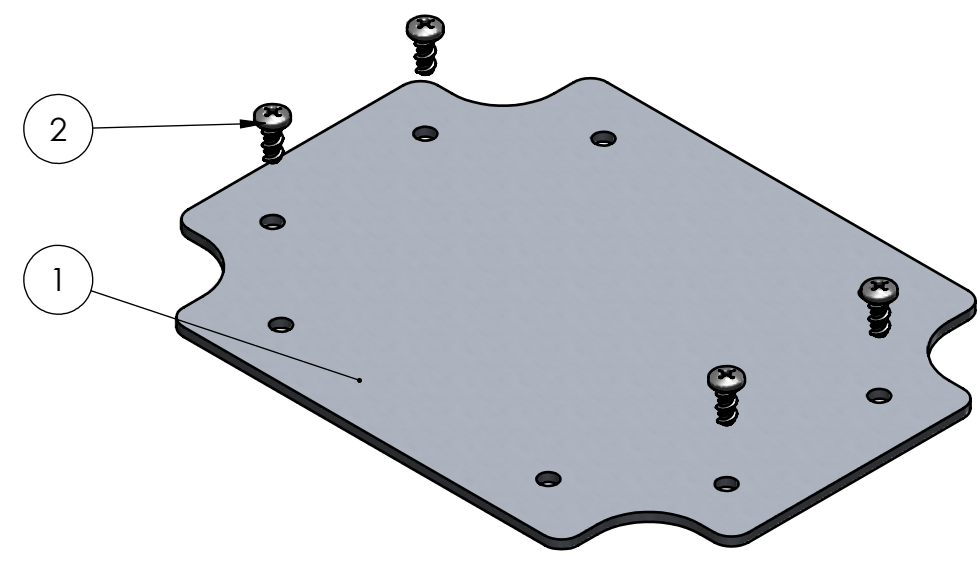

8 7 6 5 4 3 2 1

| BOM Table | | | | | |
|-----------|-------------|------|---|----------------|------|
| ITEM NO. | PART NUMBER | Rev. | Description | Material | QTY. |
| 1 | ML-34P | - | MOUNTING PANEL | AL 5052-H32 | 1 |
| 2 | SCREWS-MBR | -.01 | #4-24 HI-LO X .25 THREAD FORMING, PHILLIPS, PAN HEAD, SCREW | AISI 1019-1022 | 4 |

D
C
B
A

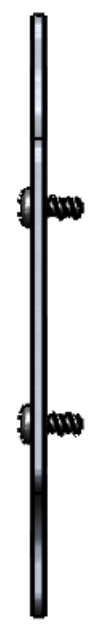
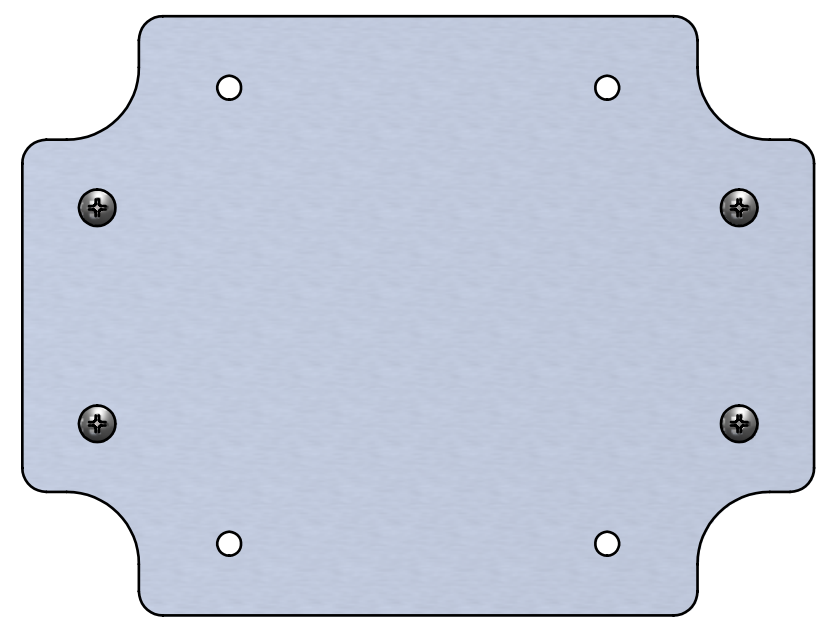

D
C
B
A

| | | | |
|--|--------------------|------------------|---|
| UNLESS OTHERWISE SPECIFIED: DIMENSIONS ARE IN: INCHES[mm] TOLERANCES: ANGULAR: ±2° TWO PLACE DECIMAL: ±.010 THREE PLACE DECIMAL: ±.005 PRINTED GRAPHICS: ±.010 | PART NO. ML-34K | |  <small>1305 CHESTER IND. PARKWAY AVON, OHIO 44011-1083 U.S.A. PH#: 1-800-248-1233, 440-934-0444 FAX#: 440-934-0088</small> |
| | MATERIAL | | |
| PROPRIETARY AND CONFIDENTIAL THE INFORMATION CONTAINED IN THIS DRAWING IS THE SOLE PROPERTY OF POLYCASE. ANY REPRODUCTION IN PART OR AS A WHOLE WITHOUT THE WRITTEN PERMISSION OF POLYCASE IS PROHIBITED. CAD FILE: ML-34K | FLAME RATING | SIZE B | MOUNTING PANEL KIT |
| | DRAWN | NAME | DATE |
| | CHECKED | D.M.F. | 2/5/2014 |
| SCALE: 1:1 | | SHEET 1 OF 1 | |

| REV. | DESCRIPTION | ZONE | BY | APPR'D | DATE |
|------|-------------|------|----|--------|------|
| | REVISIONS | | | | |

8 7 6 5 4 3 2 1

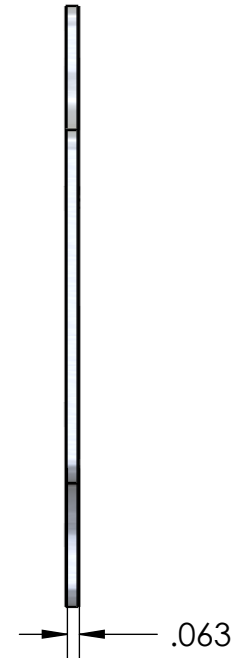
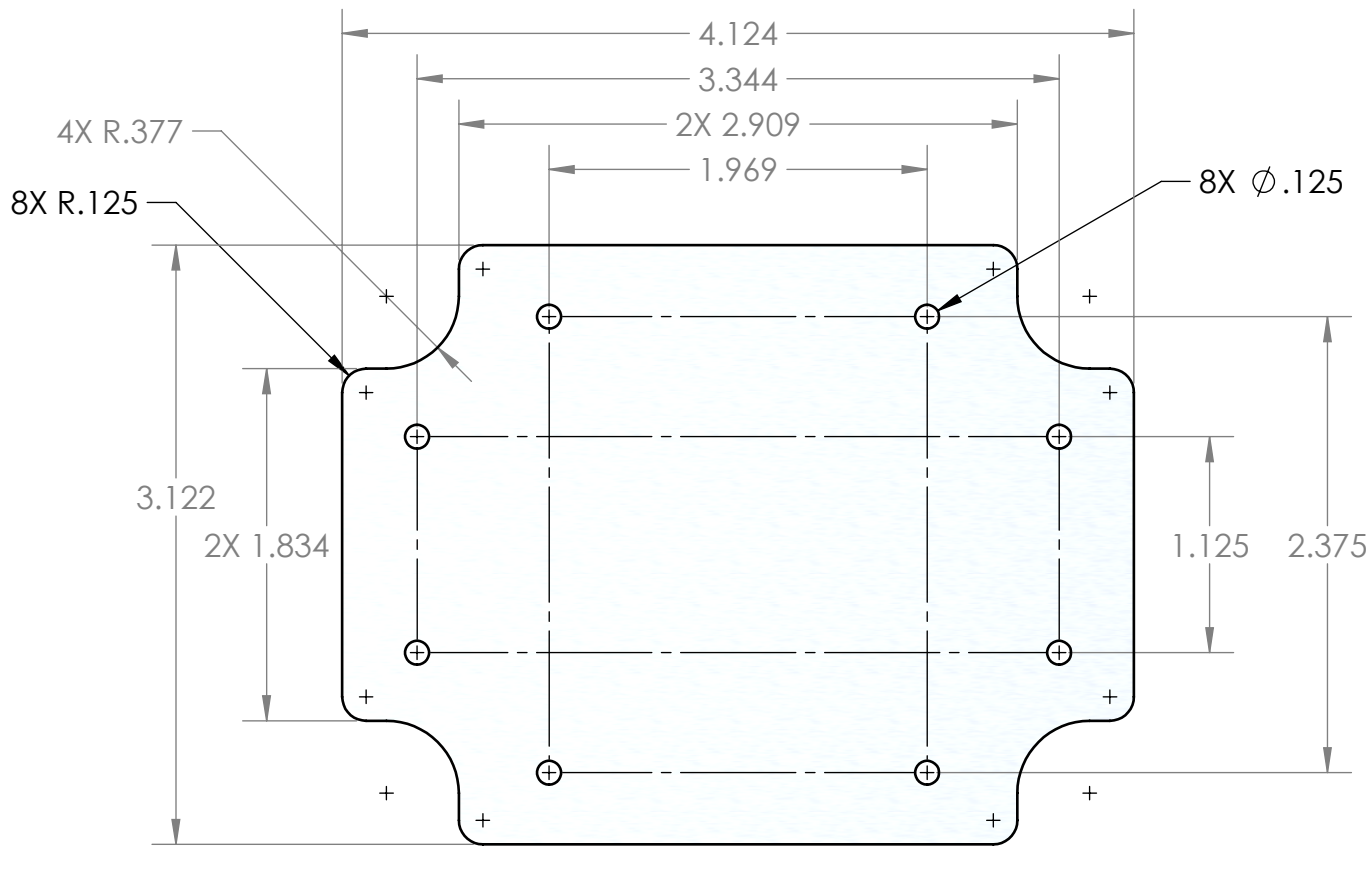

NOTES:
1. BREAK ALL EDGES .005 MAX

UNLESS OTHERWISE SPECIFIED:
DIMENSIONS ARE IN: INCHES [mm]
TOLERANCES: ANGULAR: $\pm 2^\circ$
TWO PLACE DECIMAL: $\pm .010$
THREE PLACE DECIMAL: $\pm .005$
PRINTED GRAPHICS: $\pm .010$

PROPRIETARY AND CONFIDENTIAL
THE INFORMATION CONTAINED IN THIS
DRAWING IS THE SOLE PROPERTY OF
POLYCASE. ANY REPRODUCTION IN PART
OR AS A WHOLE WITHOUT THE WRITTEN
PERMISSION OF POLYCASE IS PROHIBITED.
CAD FILE: ML-34P

PART NO.
ML-34P

MATERIAL
AL 5052-H32

FLAME RATING

SIZE
A

SCALE: 1:1

polycase
1305 CHESTER IND. PARKWAY AVON, OHIO 44011-1083 U.S.A.
PH#: 1-800-248-1233, 440-934-0444 FAX#: 440-934-0088

MOUNTING PANEL

REV
-

SHEET 1 OF 1

| REV. | DESCRIPTION | ZONE | BY | APPR'D | DATE |
|-----------|-------------|------|----|--------|------|
| REVISIONS | | | | | |

5

4

3

2

1

D

C

B

A