

BOM Table					
ITEM NO.	PART NUMBER	Rev.	Description	Material	HP-151106-PKA-W/QTY.
1	HP-151106-11	0	HINGED ENCLOSURE		1
2	PK-126A	0	POLE MOUNT KIT		1
2.1	PK-12C-00	3	MOUNTING CHANNEL	304SS	2
2.2	SCREWS-049	0	10-32 X 3/8 PHILIPS, PAN, SST	SST	4
2.3	W-002	0	FENDER WASHER .734 X .203 X .04	SST	4
2.4	CL-01	1	Hose Clamp, 2" to 12.25" ID, 30 in.-lbs. Max Torque	201 SST, ZINC SCREW	2

BOM Table					
ITEM NO.	PART NUMBER	Rev.	Description	Material	HP-151106-PKA-L/QTY.
11	HP-151106-11	0	HINGED ENCLOSURE		1
12	PK-164A	0	POLE MOUNT KIT		1
12.1	PK-16C-00	3	MOUNTING CHANNEL	304SS	2
12.2	SCREWS-049	0	10-32 X 3/8 PHILIPS, PAN, SST	SST	4
12.3	W-002	0	FENDER WASHER .734 X .203 X .04	SST	4
12.4	CL-01	1	Hose Clamp, 2" to 12.25" ID, 30 in.-lbs. Max Torque	201 SST, ZINC SCREW	2

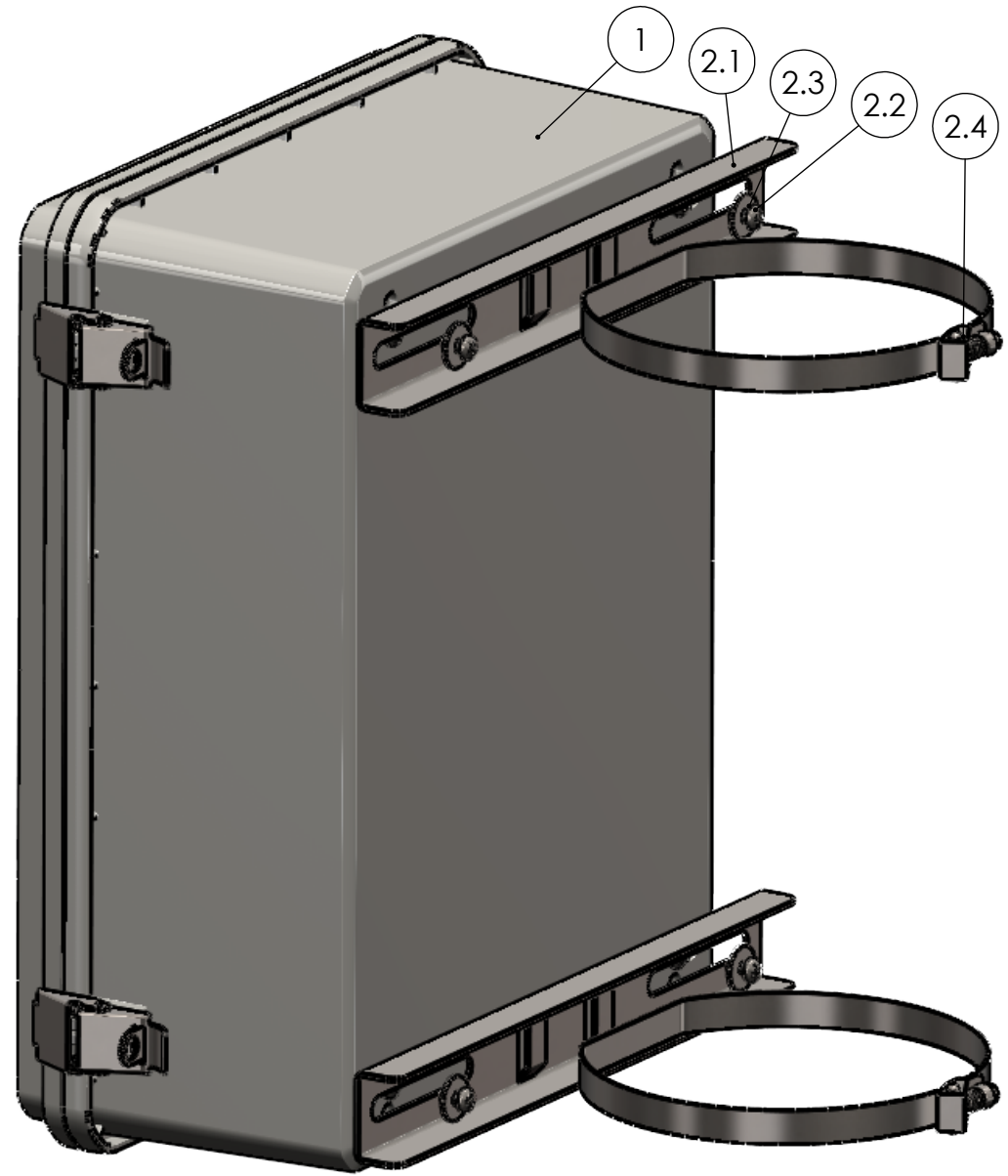

HP-151106-PKA-W

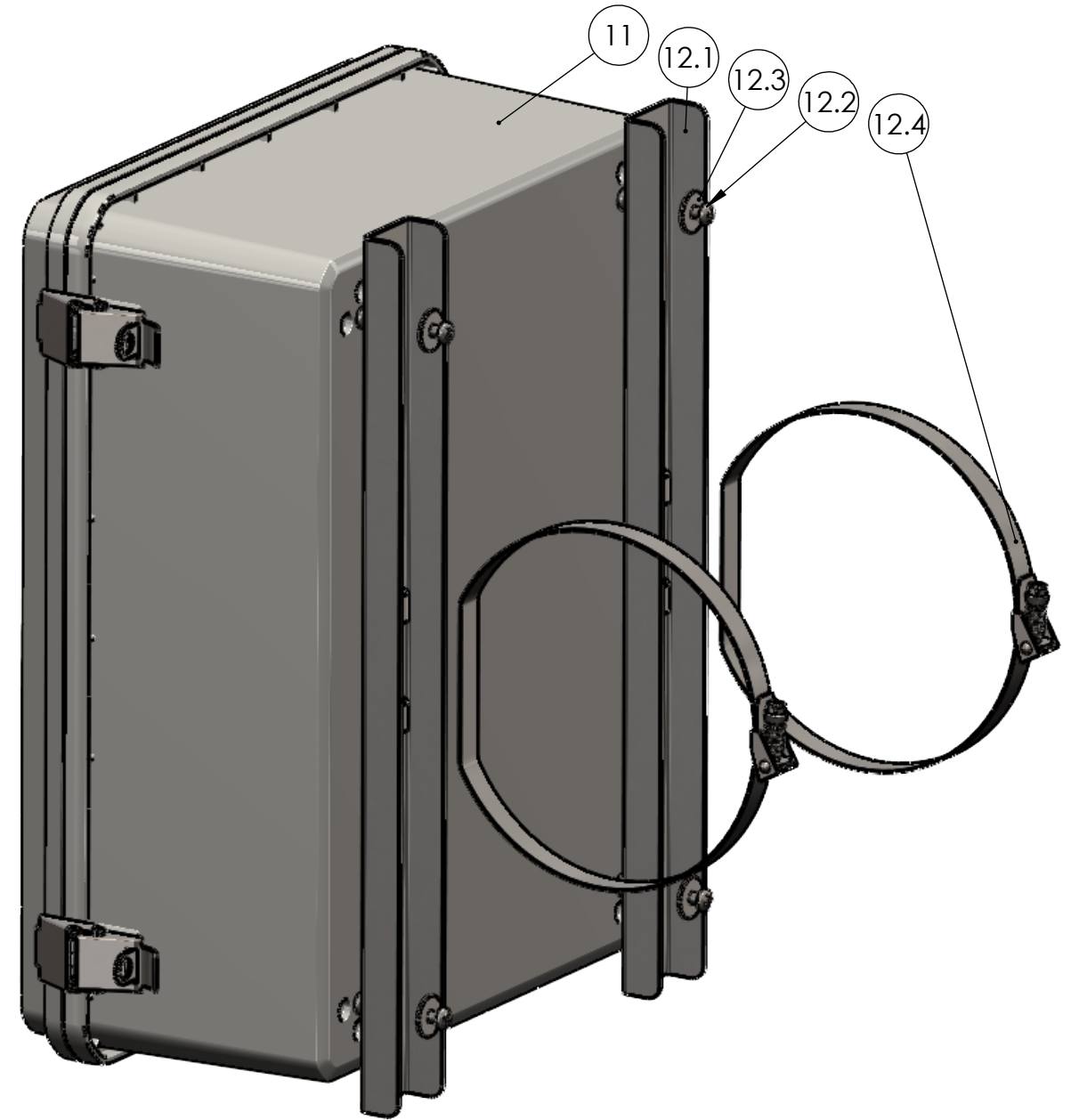

HP-151106-PKA-L

REV.	COMMENT	ZONE	REVISED BY	CREATION DATE
0			Douglas French	8-20-2024

UNLESS OTHERWISE SPECIFIED:  
 DIMENSIONS ARE IN: INCHES[mm]  
 TOLERANCES: ANGULAR: ±2°  
 TWO PLACE DECIMAL: ±.010  
 THREE PLACE DECIMAL: ±.005  
 PRINTED GRAPHICS: ±.010

PROPRIETARY AND CONFIDENTIAL  
 THE INFORMATION CONTAINED IN THIS  
 DRAWING IS THE SOLE PROPERTY OF  
 POLYCASE. ANY REPRODUCTION IN PART  
 OR AS A WHOLE WITHOUT THE WRITTEN  
 PERMISSION OF POLYCASE IS PROHIBITED.  
 CAD FILE: HP-151106-PKA

PART NO. HP-151106-PKA		MATERIAL	
FLAME RATING		SIZE <b>B</b>	ENCLOSURE W/POLE MOUNT KIT
DRAWN	NAME D.M.F.	DATE 8/20/2024	SCALE: 1:3
CHECKED	-	10/17/2023	SHEET 1 OF 2

**polycase**  
 1305 CHESTER IND. PARKWAY AVON, OHIO 44011-1083 U.S.A.  
 PH#: 1-800-248-1233, 440-934-0444 FAX#: 440-934-0088

REV **0**

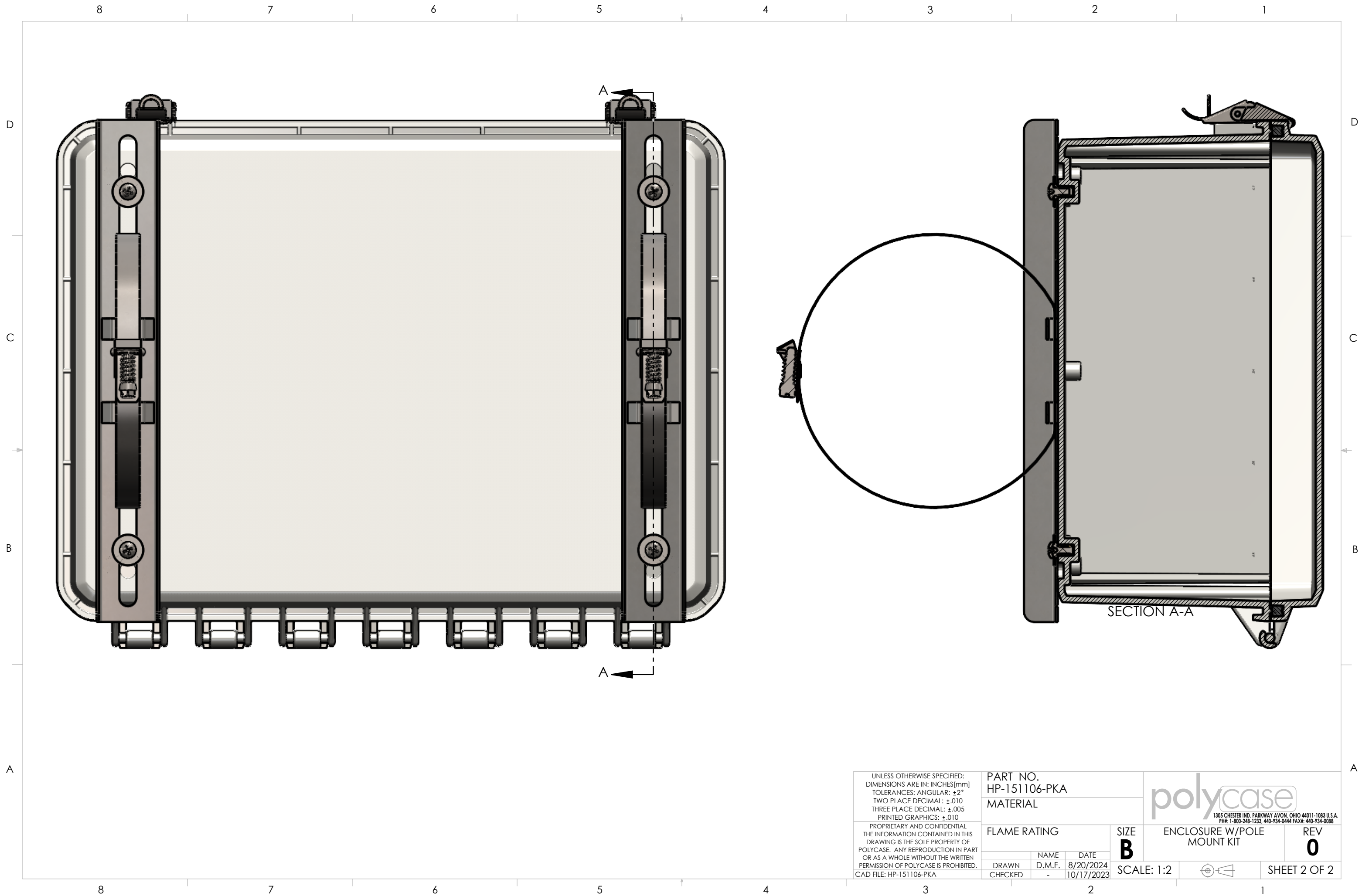

UNLESS OTHERWISE SPECIFIED:  
 DIMENSIONS ARE IN: INCHES [mm]  
 TOLERANCES: ANGULAR: ±2°  
 TWO PLACE DECIMAL: ±.010  
 THREE PLACE DECIMAL: ±.005  
 PRINTED GRAPHICS: ±.010

PROPRIETARY AND CONFIDENTIAL  
 THE INFORMATION CONTAINED IN THIS  
 DRAWING IS THE SOLE PROPERTY OF  
 POLYCASE. ANY REPRODUCTION IN PART  
 OR AS A WHOLE WITHOUT THE WRITTEN  
 PERMISSION OF POLYCASE IS PROHIBITED.  
 CAD FILE: HP-151106-PKA

PART NO. HP-151106-PKA		
MATERIAL		
FLAME RATING		
DRAWN	NAME	DATE
CHECKED	-	8/20/2024 10/17/2023

**polycase**  
 1305 CHESTER IND. PARKWAY AVON, OHIO 44011-1083 U.S.A.  
 PH#: 1-800-248-1233, 440-934-0444 FAX#: 440-934-0088

ENCLOSURE W/POLE MOUNT KIT	REV <b>0</b>
-------------------------------	-----------------

SCALE: 1:2

SHEET 2 OF 2