

BOM Table					
ITEM NO.	PART NUMBER	Rev.	Description	Material	HP-070705-PKA-W/QTY.
1	HP-070705-11	0	HINGED ENCLOSURE		1
2	PK-067A	0	POLE MOUNT KIT		1
2.1	PK-06C-00	3	MOUNTING CHANNEL	304SS	2
2.2	SCREWS-049	0	10-32 X 3/8 PHILIPS, PAN, SST	SST	4
2.3	W-002	0	FENDER WASHER .734 X .203 X .04	SST	4
2.4	CL-01	1	Hose Clamp, 2" to 12.25" ID, 30 in.-lbs. Max Torque	201 SST, ZINC SCREW	2

BOM Table					
ITEM NO.	PART NUMBER	Rev.	Description	Material	HP-070705-PKA-L/QTY.
11	HP-070705-11	0	HINGED ENCLOSURE		1
12	PK-067A	0	POLE MOUNT KIT		1
12.1	PK-06C-00	3	MOUNTING CHANNEL	304SS	2
12.2	SCREWS-049	0	10-32 X 3/8 PHILIPS, PAN, SST	SST	4
12.3	W-002	0	FENDER WASHER .734 X .203 X .04	SST	4
12.4	CL-01	1	Hose Clamp, 2" to 12.25" ID, 30 in.-lbs. Max Torque	201 SST, ZINC SCREW	2

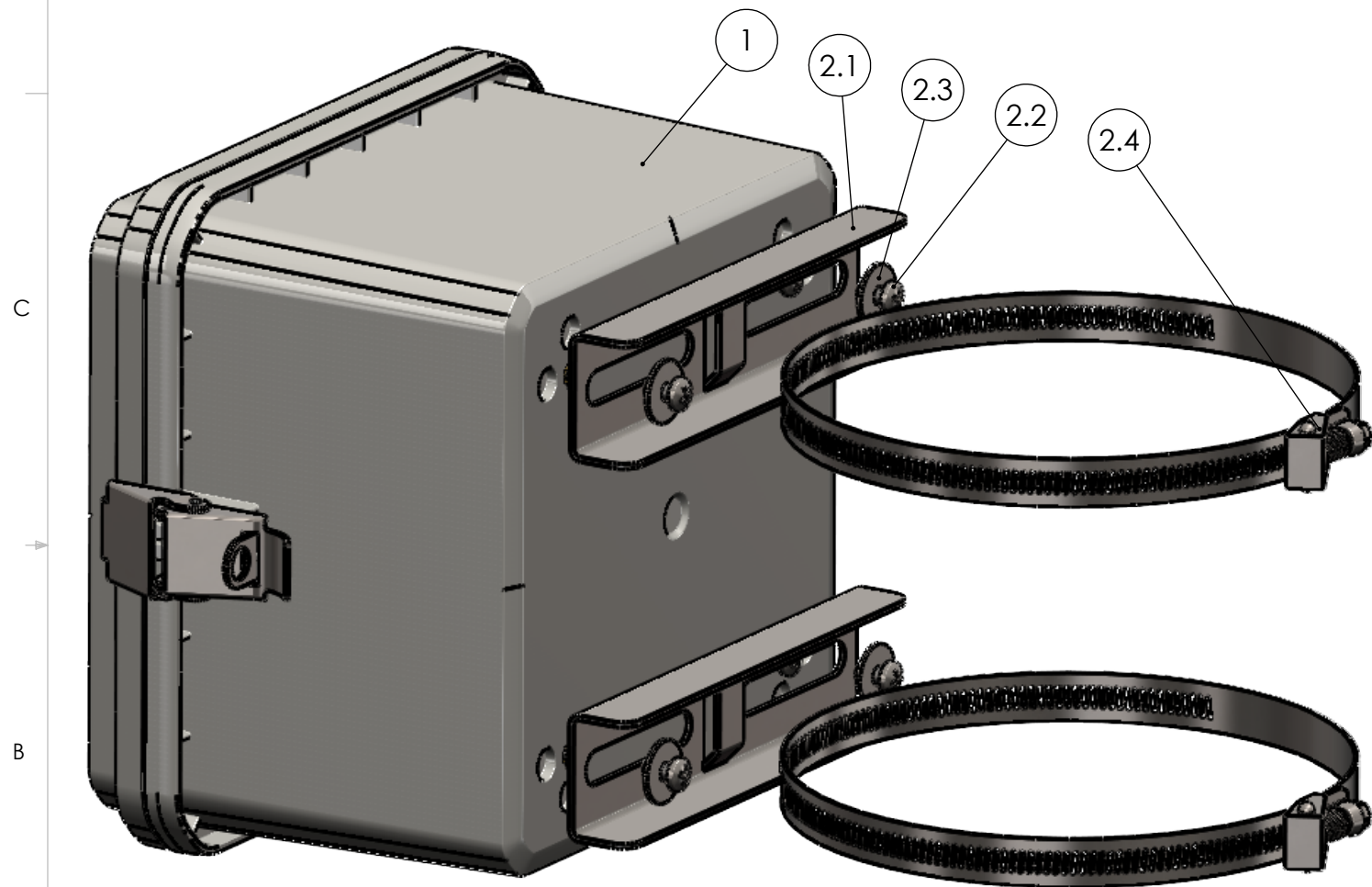

HP-070705-PKA-W

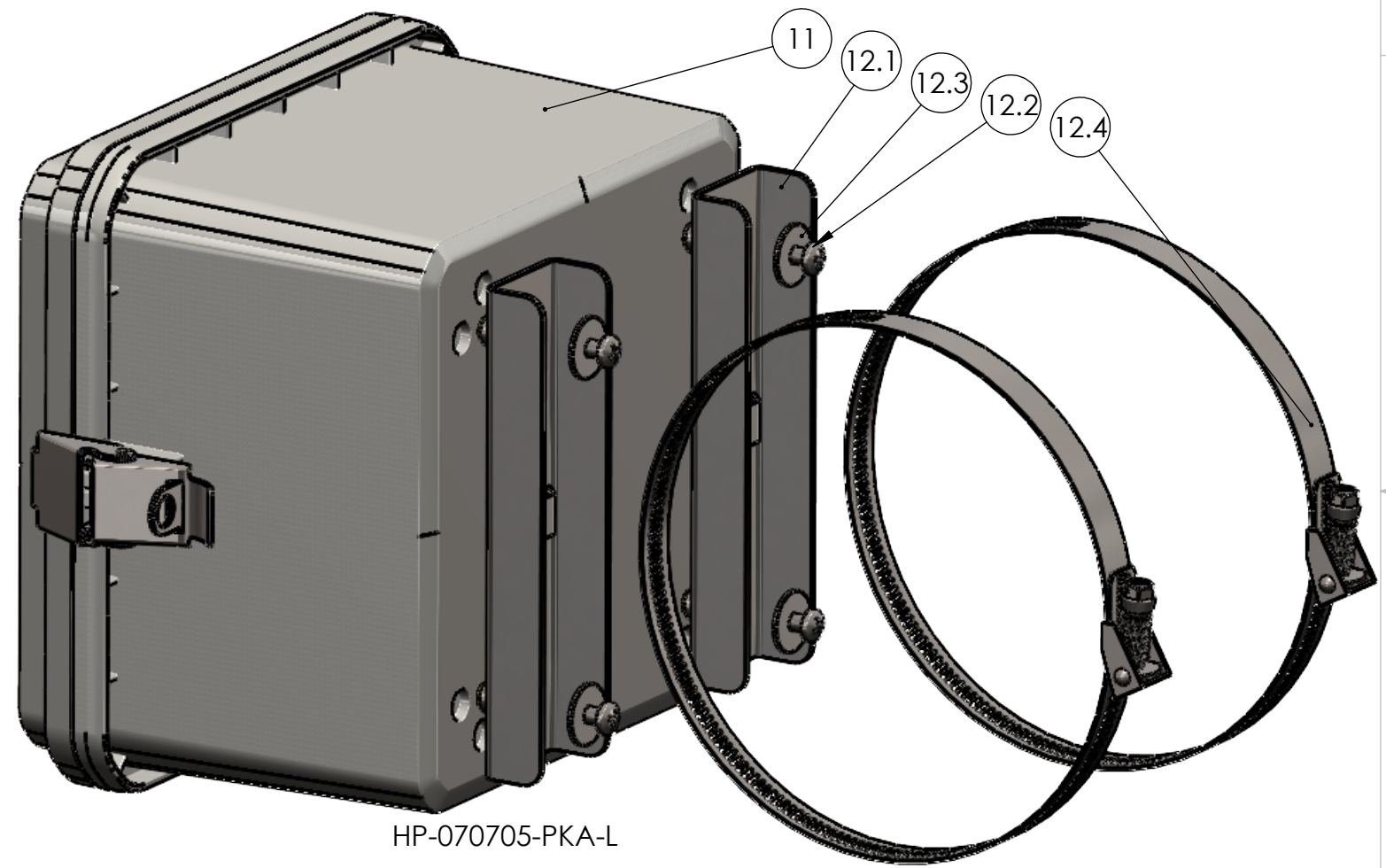

HP-070705-PKA-L

REV.	COMMENT	ZONE	REVISED BY	CREATION DATE
0			Douglas French	8-20-2024

REVISIONS

UNLESS OTHERWISE SPECIFIED:
 DIMENSIONS ARE IN: INCHES [mm]
 TOLERANCES: ANGULAR: ±2°
 TWO PLACE DECIMAL: ±.010
 THREE PLACE DECIMAL: ±.005
 PRINTED GRAPHICS: ±.010

PROPRIETARY AND CONFIDENTIAL
 THE INFORMATION CONTAINED IN THIS
 DRAWING IS THE SOLE PROPERTY OF
 POLYCASE. ANY REPRODUCTION IN PART
 OR AS A WHOLE WITHOUT THE WRITTEN
 PERMISSION OF POLYCASE IS PROHIBITED.
 CAD FILE: HP-070705-PKA

PART NO. HP-070705-PKA		MATERIAL	
FLAME RATING		SIZE B	ENCLOSURE W/POLE MOUNT KIT
DRAWN	NAME D.M.F.	DATE 8/20/2024	REV 0
CHECKED	-	10/17/2023	SHEET 1 OF 2

 1305 CHESTER IND. PARKWAY AVON, OHIO 44011-1083 U.S.A.
 PH#: 1-800-248-1233, 440-934-0444 FAX#: 440-934-0088

SCALE: 1:2

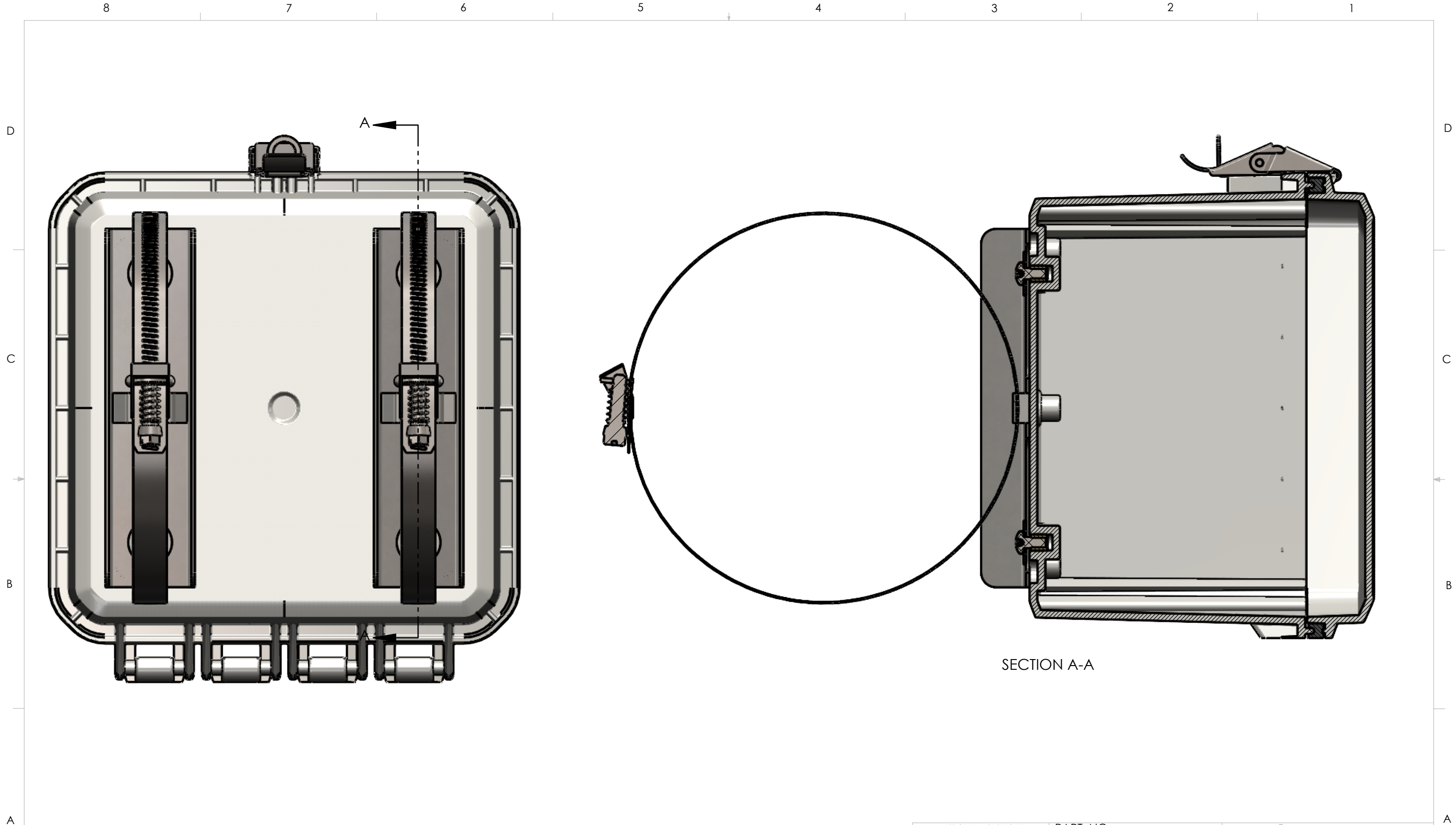

SECTION A-A

UNLESS OTHERWISE SPECIFIED:
 DIMENSIONS ARE IN: INCHES [mm]
 TOLERANCES: ANGULAR: ±2°
 TWO PLACE DECIMAL: ±.010
 THREE PLACE DECIMAL: ±.005
 PRINTED GRAPHICS: ±.010

PROPRIETARY AND CONFIDENTIAL
 THE INFORMATION CONTAINED IN THIS
 DRAWING IS THE SOLE PROPERTY OF
 POLYCASE. ANY REPRODUCTION IN PART
 OR AS A WHOLE WITHOUT THE WRITTEN
 PERMISSION OF POLYCASE IS PROHIBITED.
 CAD FILE: HP-070705-PKA

PART NO. HP-070705-PKA		
MATERIAL		
FLAME RATING		
DRAWN	NAME	DATE
CHECKED	-	8/20/2024 10/17/2023

polycase
 1305 CHESTER IND. PARKWAY AVON, OHIO 44011-1083 U.S.A.
 PH#: 1-800-248-1233, 440-934-0444 FAX#: 440-934-0088

ENCLOSURE W/POLE MOUNT KIT	REV 0
----------------------------	-----------------

SCALE: 1:1.5

SHEET 2 OF 2