

ZH/ZQ POLE MOUNT INSTALL

BOM Table					
ITEM NO.	PART NUMBER	Rev.	Description	Material	QTY.
1	ZH-xxxx-01	0	HINGED ENCLOSURE		1
2	PK-XXX	0	POLE MOUNT KIT		1
2.1	SC-080	0	Strut Channel P4100SLPG	PRE-GALV STEEL	2
2.2	SW-001	0	Strut Channel Washer 1/4	304 SST	4
2.3	SCREWS-031	0	1/4-20 X .75 PAN HEAD, PHILLIPS, SS	SST	4
2.4	SCREWS-049	0	10-32 X 3/8 PHILLIPS, PAN, SST	SST	4
2.5	W-002		FENDER WASHER #10 X .734 X .04	SST	4
2.6	SN-001	0	Strut Channel NUT 1/4-20	316 SST	4
2.7	CL-01	0	Hose Clamp, 2" to 12.25" ID, 30 in.-lbs. Max Torque	201 SST, ZINC SCREW	2

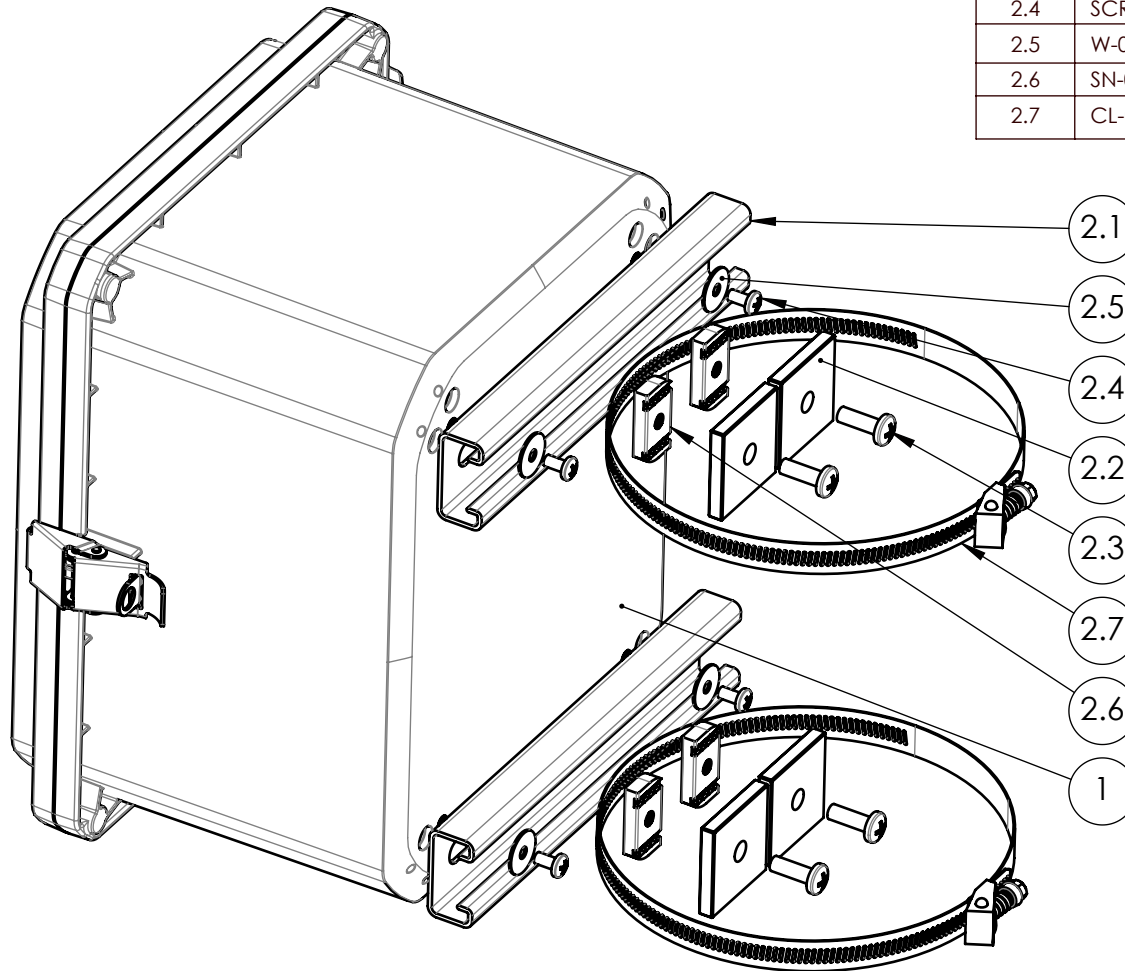

UNLESS OTHERWISE SPECIFIED:
 DIMENSIONS ARE IN: INCHES[mm]
 TOLERANCES: ANGULAR: ±2°
 TWO PLACE DECIMAL: ±.010
 THREE PLACE DECIMAL: ±.005
 PRINTED GRAPHICS: ±.010

PROPRIETARY AND CONFIDENTIAL
 THE INFORMATION CONTAINED IN THIS
 DRAWING IS THE SOLE PROPERTY OF
 POLYCASE. ANY REPRODUCTION IN PART
 OR AS A WHOLE WITHOUT THE WRITTEN
 PERMISSION OF POLYCASE IS PROHIBITED.
 CAD FILE: ZH-PK-INST-00

PART NO.
 ZH-PK-INST-00
 MATERIAL

polycase
 1305 CHESTER IND. PARKWAY AVON, OHIO 44011-1083 U.S.A.
 PH#: 1-800-248-1233, 440-934-0444 FAX#: 440-934-0088

FLAME RATING: **A** SIZE: **A** ENCLOSURE W/POLE MOUNT KIT REV: **0**

DRAWN: D.M.F. 1/6/2020
 CHECKED: B.M.B. 1/16/2020

SCALE: 1:3

SHEET 1 OF 1

REV.	DESCRIPTION	ZONE	BY	APPR'D	DATE
	REVISIONS				

5

4

3

2

1