

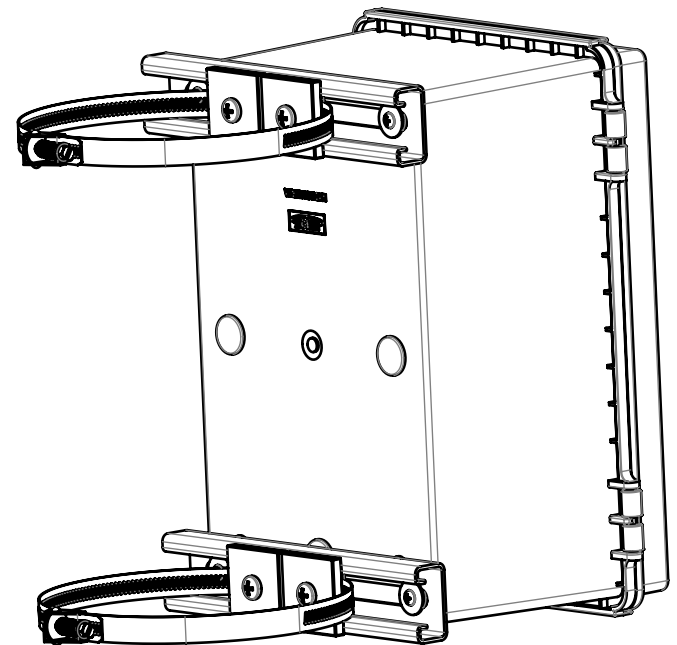

BOM Table					
ITEM NO.	PART NUMBER	Rev.	Description	Material	QTY.
1	WH-xx	0	Hinged Nema Enclosure, Indoor/Outdoor Use, with Flange Kit		1
2	PK-xxx	0	POLE MOUNT KIT		1
2.1	SC-080	0	Strut Channel P4100SLPG	PRE-GALV STEEL	2
2.2	SW-001	0	Strut Channel Washer 1/4	304 SST	4
2.3	SCREWS-031	0	1/4-20 X .75 PAN HEAD, PHILLIPS, SS	SST	4
2.4	W-002		FENDER WASHER #10 X .734 X .04	SST	4
2.5	SN-001	0	Strut Channel NUT 1/4-20	316 SST	4
2.6	CL-01	0	Hose Clamp, 2" to 12.25" ID, 30 in.-lbs. Max Torque	201 SST, ZINC SCREW	2
2.7	SCREWS-044	0	#8-16 X 1/2 PLASTITE, PAN HEAD, PHILLIPS, SST	SST	4

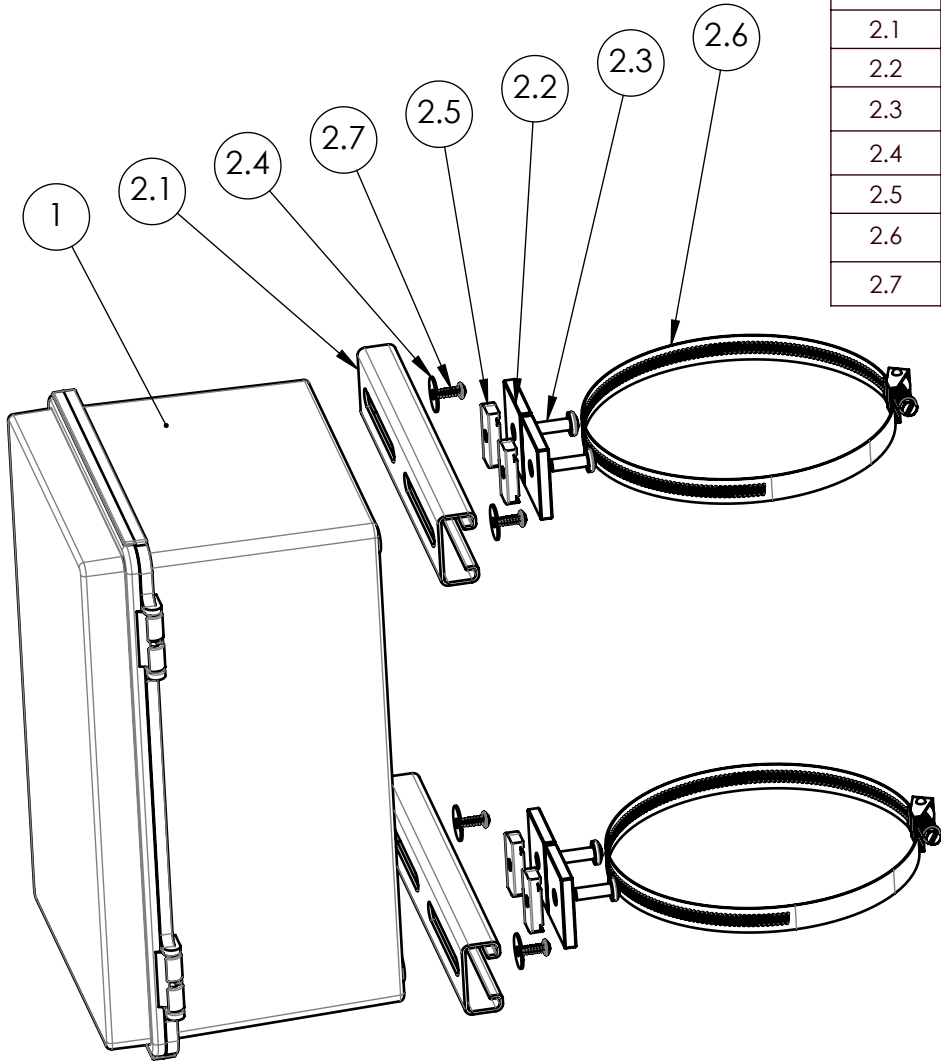

UNLESS OTHERWISE SPECIFIED: DIMENSIONS ARE IN: INCHES[mm] TOLERANCES: ANGULAR: ±2° TWO PLACE DECIMAL: ±.010 THREE PLACE DECIMAL: ±.005 PRINTED GRAPHICS: ±.010	PART NO. PK-INST-05		 <small>1305 CHESTER IND. PARKWAY AVON, OHIO 44011-1083 U.S.A. PH#: 1-800-248-1233, 440-934-0444 FAX#: 440-934-0088</small>
	MATERIAL		
PROPRIETARY AND CONFIDENTIAL THE INFORMATION CONTAINED IN THIS DRAWING IS THE SOLE PROPERTY OF POLYCASE. ANY REPRODUCTION IN PART OR AS A WHOLE WITHOUT THE WRITTEN PERMISSION OF POLYCASE IS PROHIBITED. CAD FILE: PK-INST-05	FLAME RATING	SIZE A	REV 0
	DRAWN CHECKED	NAME R.W.H. C.C.B.	DATE 10/20/2017 10/23/2017
SCALE: 1:4		SHEET 1 OF 1	

REV.	DESCRIPTION	ZONE	BY	APPR'D	DATE
	REVISIONS				

5

4

3

2

1

D
C
B
A