

BOM Table					
ITEM NO.	PART NUMBER	Rev.	Description	Material	QTY.
1	WQ-xx	0	Hinged Nema Enclosure, Outdoor Use, with Screw Kit		1
2	PK-xxx	0	POLE MOUNT KIT		1
2.1	SC-080	0	Strut Channel P4100SLPG	PRE-GALV STEEL	2
2.2	SW-001	0	Strut Channel Washer 1/4 1/4-20 X .75 PAN HEAD, PHILLIPS, SS	304 SST	4
2.3	SCREWS-031		FENDER WASHER 1/4 X 1.00 X .050	SST	4
2.4	W-001		Strut Channel NUT 1/4-20	SST	4
2.5	SN-001	0	Hose Clamp, 2" to 12.25" ID, 30 in.-lbs. Max Torque	316 SST	4
2.6	CL-01	0	CR PHMS M5x0.8 x 10mm	201 SST, ZINC SCREW	2
2.7	SCREWS-042			SST	4

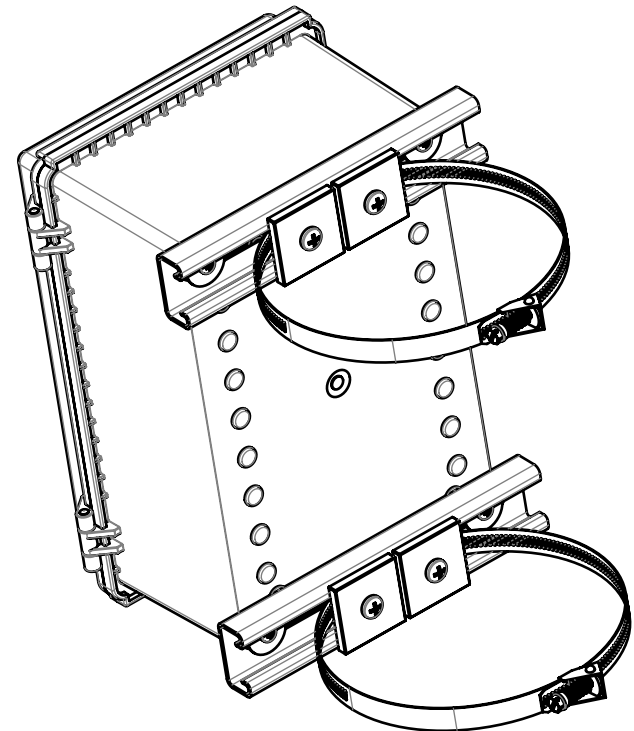
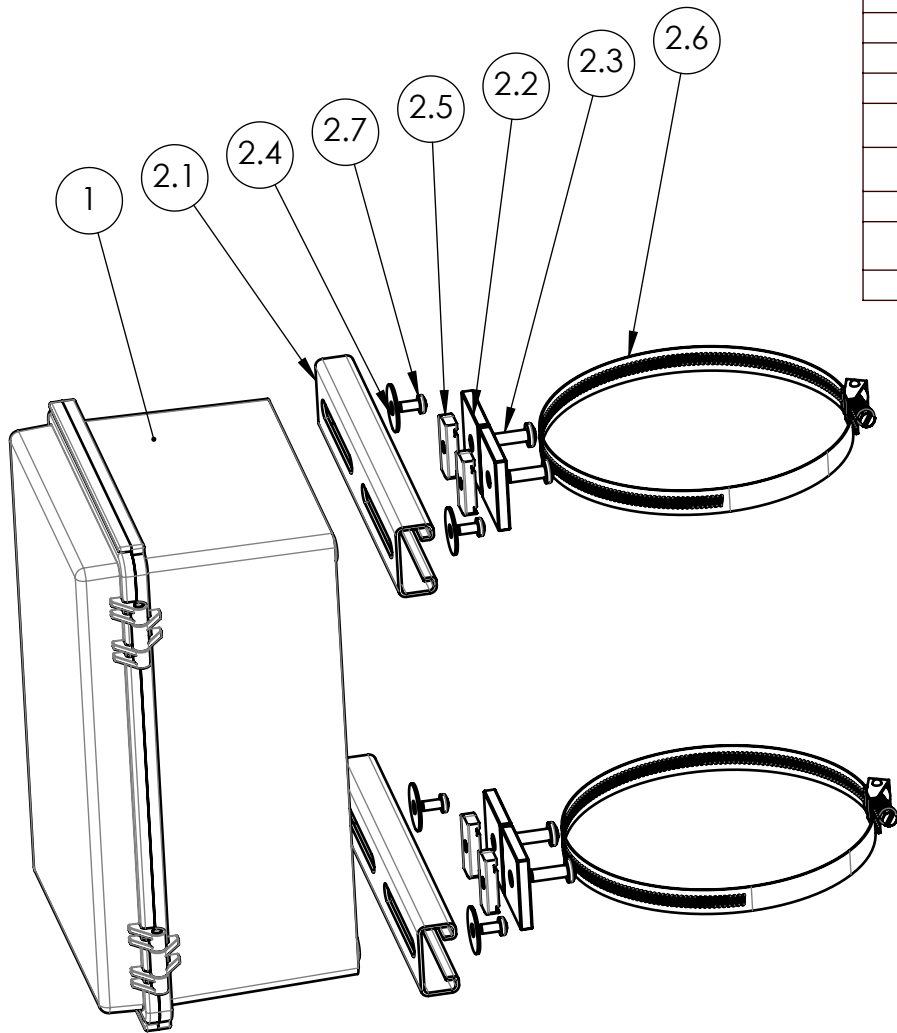

UNLESS OTHERWISE SPECIFIED:  
 DIMENSIONS ARE IN: INCHES[mm]  
 TOLERANCES: ANGULAR: ±2°  
 TWO PLACE DECIMAL: ±.010  
 THREE PLACE DECIMAL: ±.005  
 PRINTED GRAPHICS: ±.010

PROPRIETARY AND CONFIDENTIAL  
 THE INFORMATION CONTAINED IN THIS  
 DRAWING IS THE SOLE PROPERTY OF  
 POLYCASE. ANY REPRODUCTION IN PART  
 OR AS A WHOLE WITHOUT THE WRITTEN  
 PERMISSION OF POLYCASE IS PROHIBITED.  
 CAD FILE: PK-INST-03

PART NO.  
 PK-INST-03

MATERIAL

FLAME RATING

SIZE  
**A**

SCALE: 1:4

NAME DATE  
 DRAWN R.W.H. 10/20/2017  
 CHECKED C.C.B. 10/23/2017

**polycase**  
 1305 CHESTER IND. PARKWAY AVON, OHIO 44011-1083 U.S.A.  
 PH#: 1-800-248-1233, 440-934-0444 FAX#: 440-934-0088

REV  
**0**

SHEET 1 OF 1

REV.	DESCRIPTION	ZONE	BY	APPR'D	DATE
	REVISIONS				

5

4

3

2

1