

BOM Table						
ITEM NO.	PART NUMBER	Rev.	Description	Material	Color	QTY.
1	SK-20B-02	-	BASE	GFR/PC	LIGHT GRAY	1
2	SK-20C-02	-	COVER	GFR/PC	LIGHT GRAY	1
3	SK-KIT-03	-	HARDWARE KIT			1
3.1	SCREWS-014	-	ASSEMBLY FASTENER	GFR/PA6	GRAY	4
3.2	SK-CAP-02	-	SCREW HEAD CAP		CLEAR	4

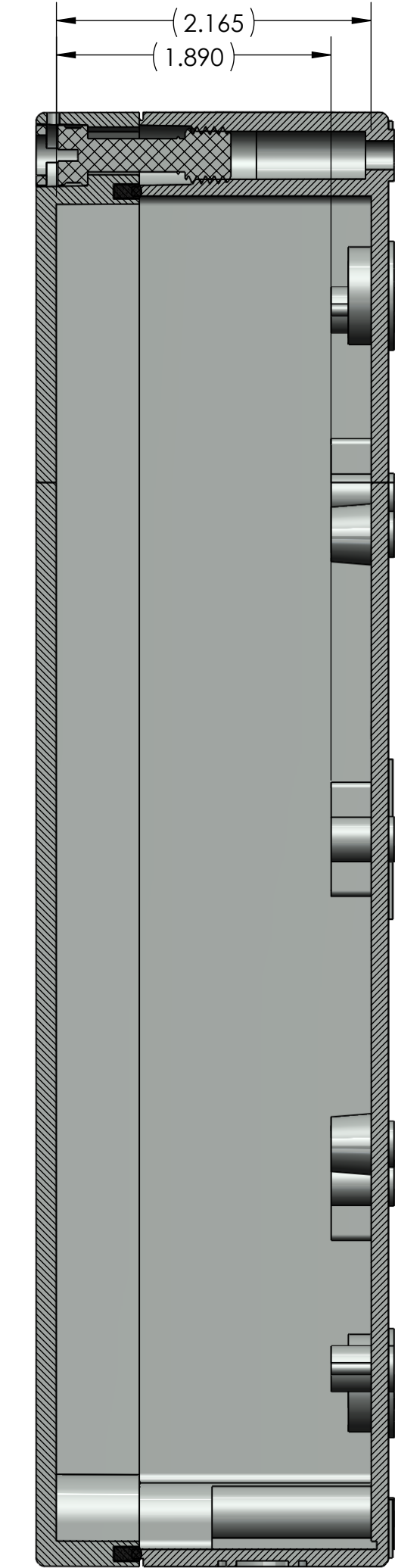

SECTION B-B

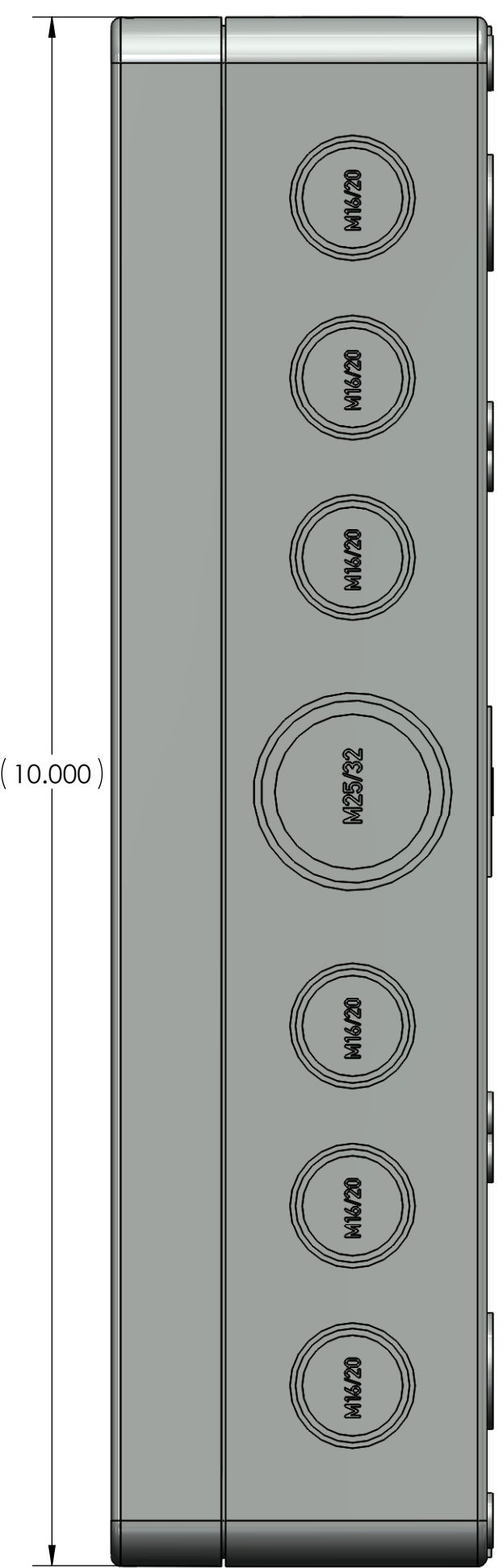
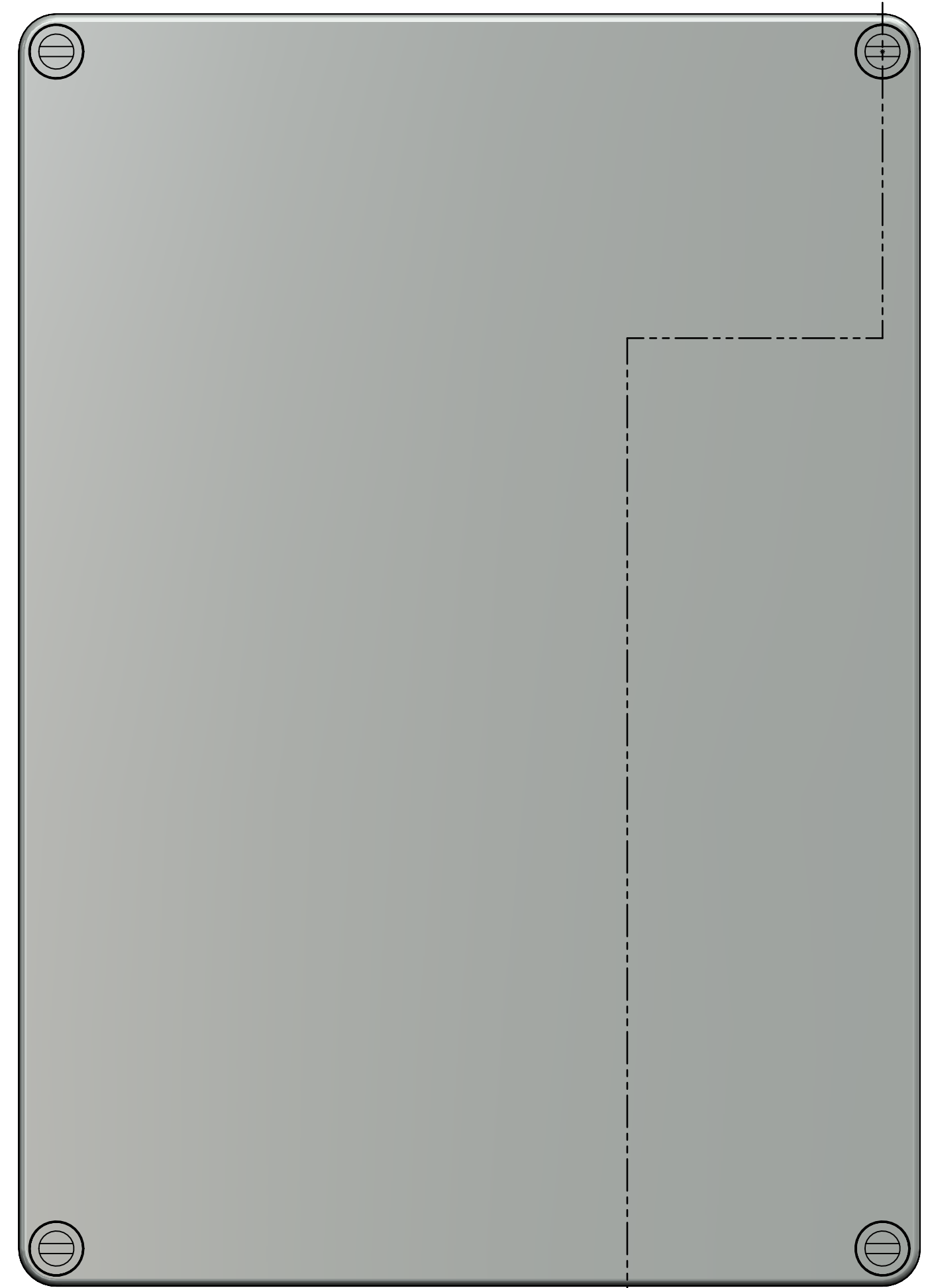
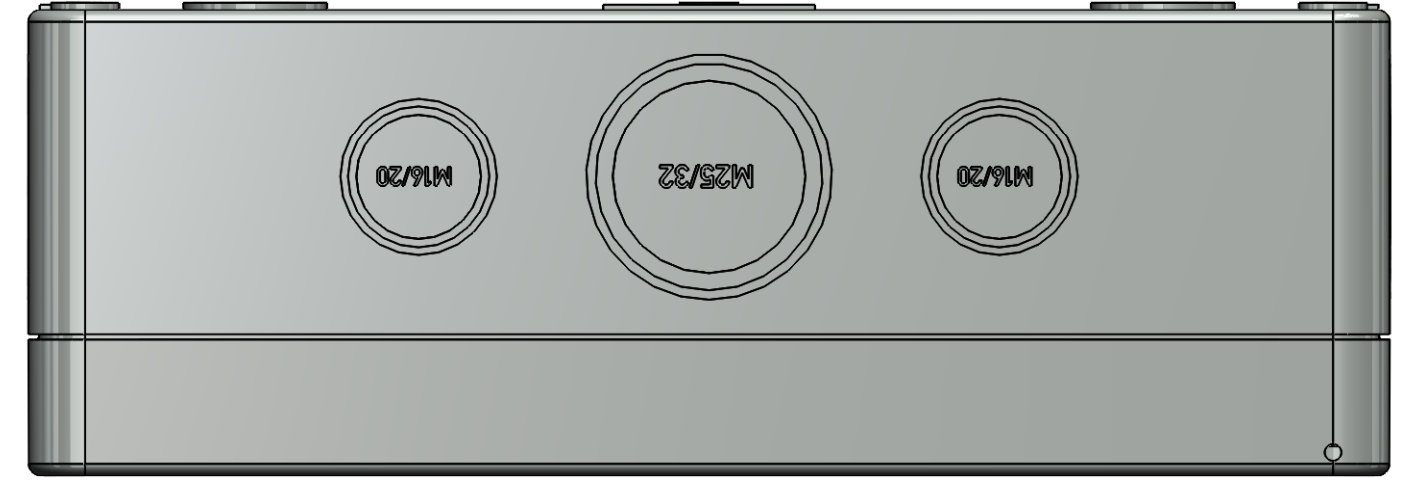
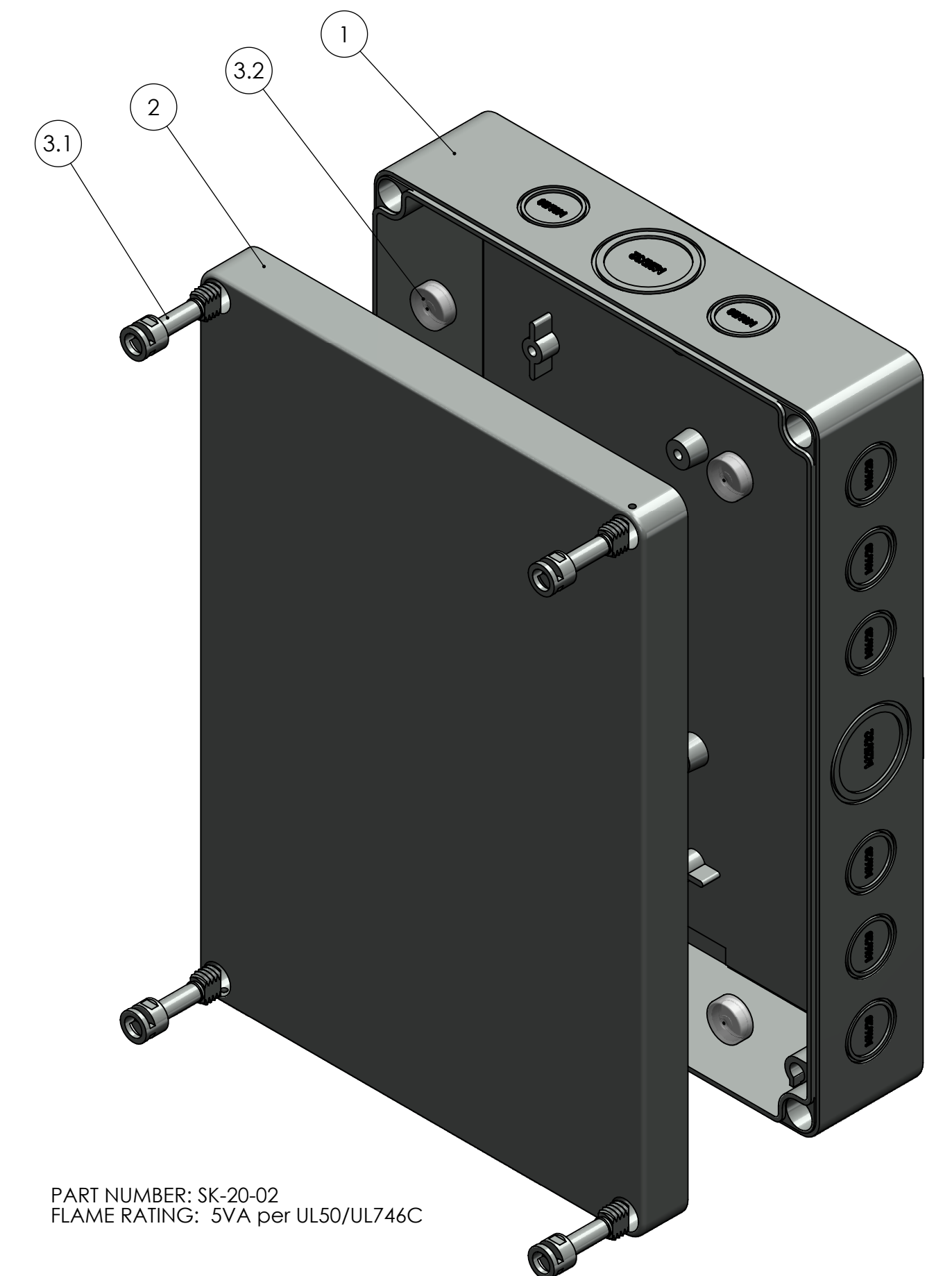

PART NUMBER: SK-20-02
FLAME RATING: 5VA per UL50/UL746C

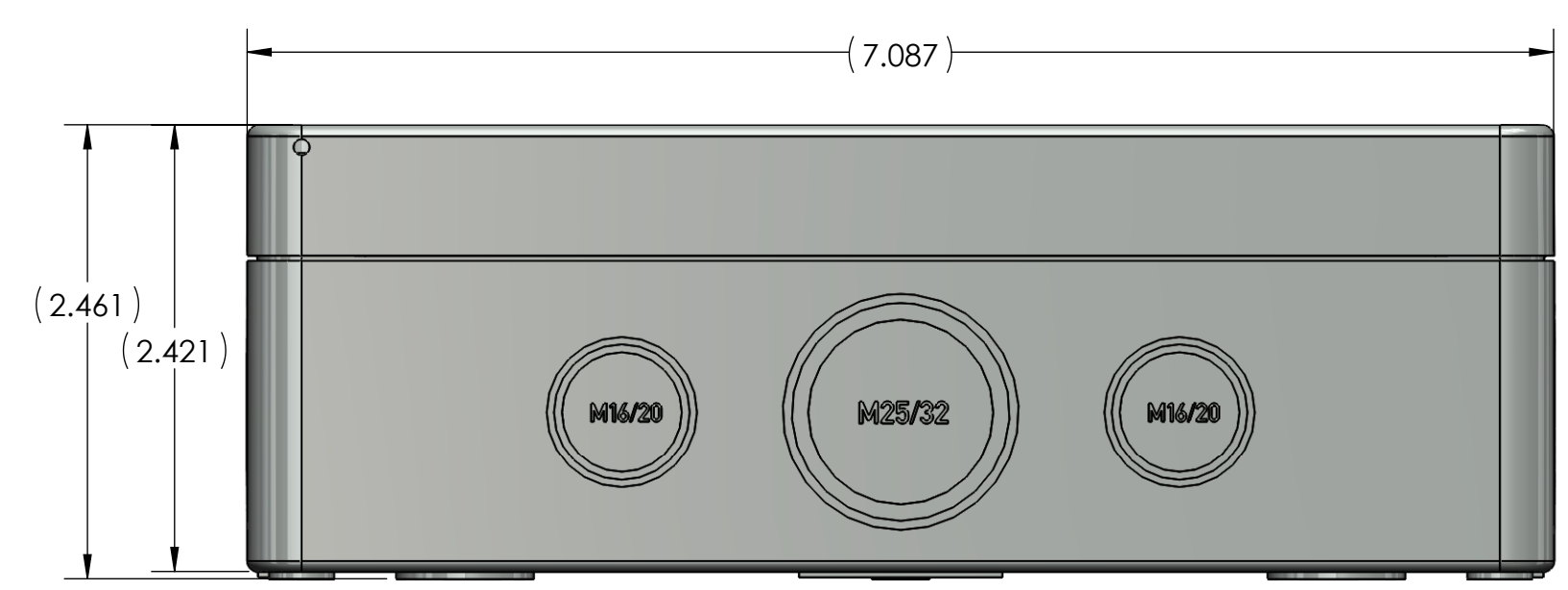

UNLESS OTHERWISE SPECIFIED:
DIMENSIONS ARE IN INCHES (mm)
TOLERANCES: ANGULAR: 22°
TWO PLACE DECIMAL: ±.010
THREE PLACE DECIMAL: ±.005
PRINTED GRAPHICS: 1:500

PROPERTY AND CONFIDENTIAL
THE INFORMATION CONTAINED IN THIS
DRAWING IS THE SOLE PROPERTY OF
POLYCASE. ANY REPRODUCTION IN PART
OR AS A WHOLE WITHOUT THE WRITTEN
PERMISSION OF POLYCASE IS PROHIBITED.
CAPITAL SK-20

REV.	DESCRIPTION	ZONE	BY	APPR'D	DATE
	REVISIONS				

PART NO. SEE BOM
MATERIAL SEE BOM

FLAME RATING: 5VA
SIZE: D

SCALE: 1:1

SHEET 1 OF 2

polycase
100 CROSS BAY TOWER FLOOR 2000 WILLOW AVE
MILWAUKEE, WI 53217
PHONE: 414.354.1234 FAX: 414.354.1235

NAME: D.M.F. DATE: 8/25/2013
DRAWN: 2/5/2013
CHECKED: -

BOM Table						
ITEM NO.	PART NUMBER	Rev.	Description	Material	Color	QTY.
1	SK-20B-02	-	BASE	GFR/PC	LIGHT GRAY	1
2	SK-20C-03	-	COVER	PC	CLEAR	1
3	SK-KIT-04	-	HARDWARE KIT			1
3.1	SCREWS-015	-	ASSEMBLY FASTENER	GFR/PA6	BLACK	4
3.2	SK-CAP-02	-	SCREW HEAD CAP		CLEAR	4

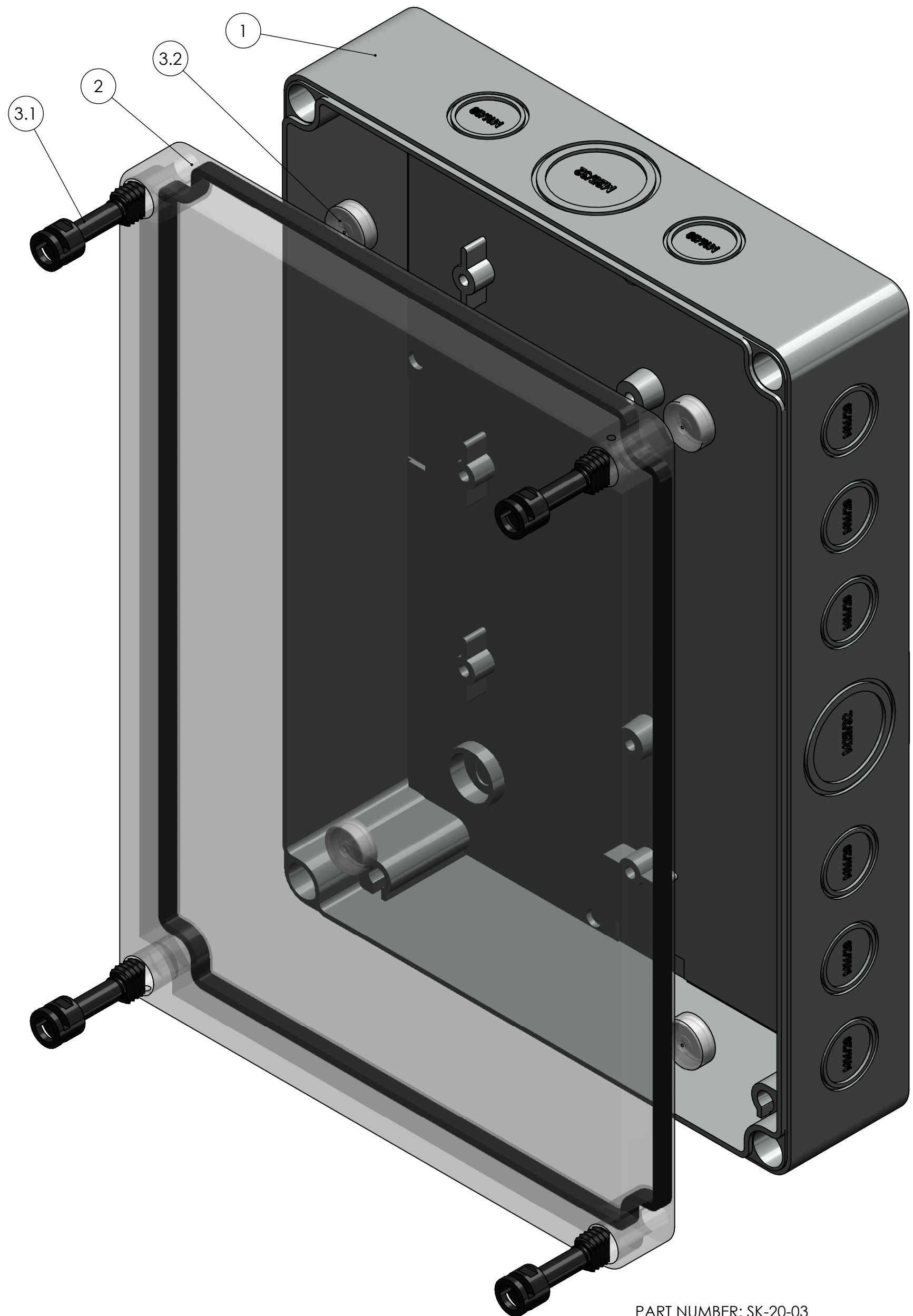

PART NUMBER: SK-20-03
 FLAME RATING: 5VA per UL50/UL746C

UNLESS OTHERWISE SPECIFIED: DIMENSIONS ARE IN: INCHES[mm] TOLERANCES: ANGULAR: ±2° TWO PLACE DECIMAL: ±.010 THREE PLACE DECIMAL: ±.005 PRINTED GRAPHICS: ±.010	PART NO. SEE BOM		polycase 1305 CHESTER RD. PARKWAY AVON, OHIO 44011-1083 U.S.A. PH: 1-800-248-1233 440-934-0444 FAX: 440-934-0088
	MATERIAL SEE BOM		
PROPRIETARY AND CONFIDENTIAL THE INFORMATION CONTAINED IN THIS DRAWING IS THE SOLE PROPERTY OF POLYCASE. ANY REPRODUCTION IN PART OR AS A WHOLE WITHOUT THE WRITTEN PERMISSION OF POLYCASE IS PROHIBITED. CAD FILE: SK-20	FLAME RATING SEE BOM		REV -
	DRAWN CHECKED	NAME D.M.F.	DATE 8/25/2015 2/5/2013
SCALE: 1:1		SIZE C	SHEET 2 OF 2

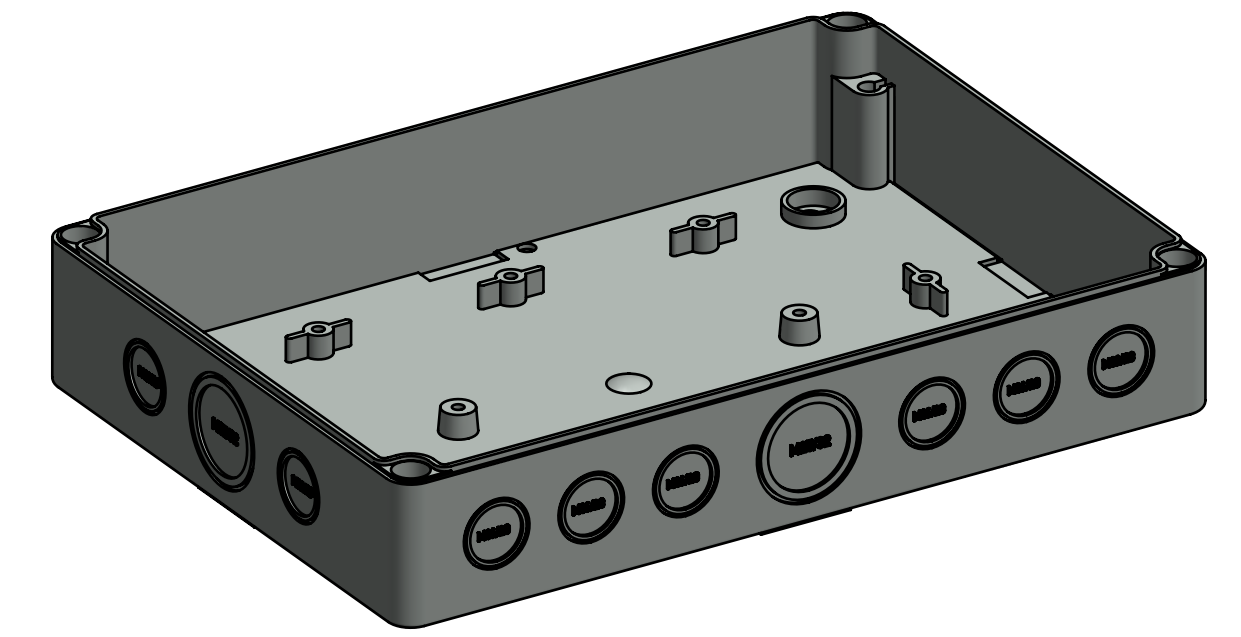
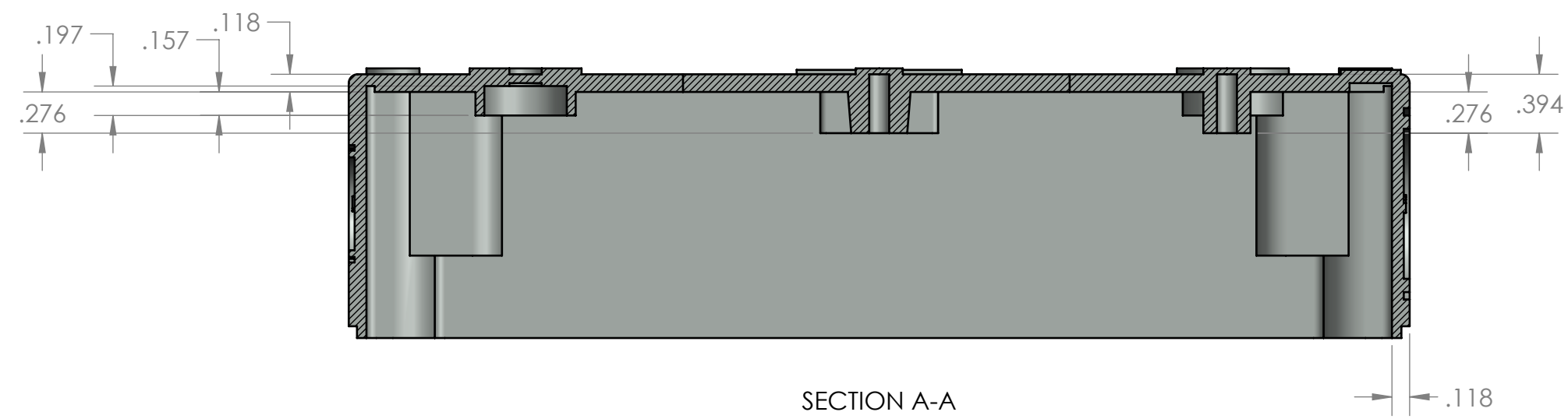

PART NUMBER: SK-20B-02
COLOR: LIGHT GRAY

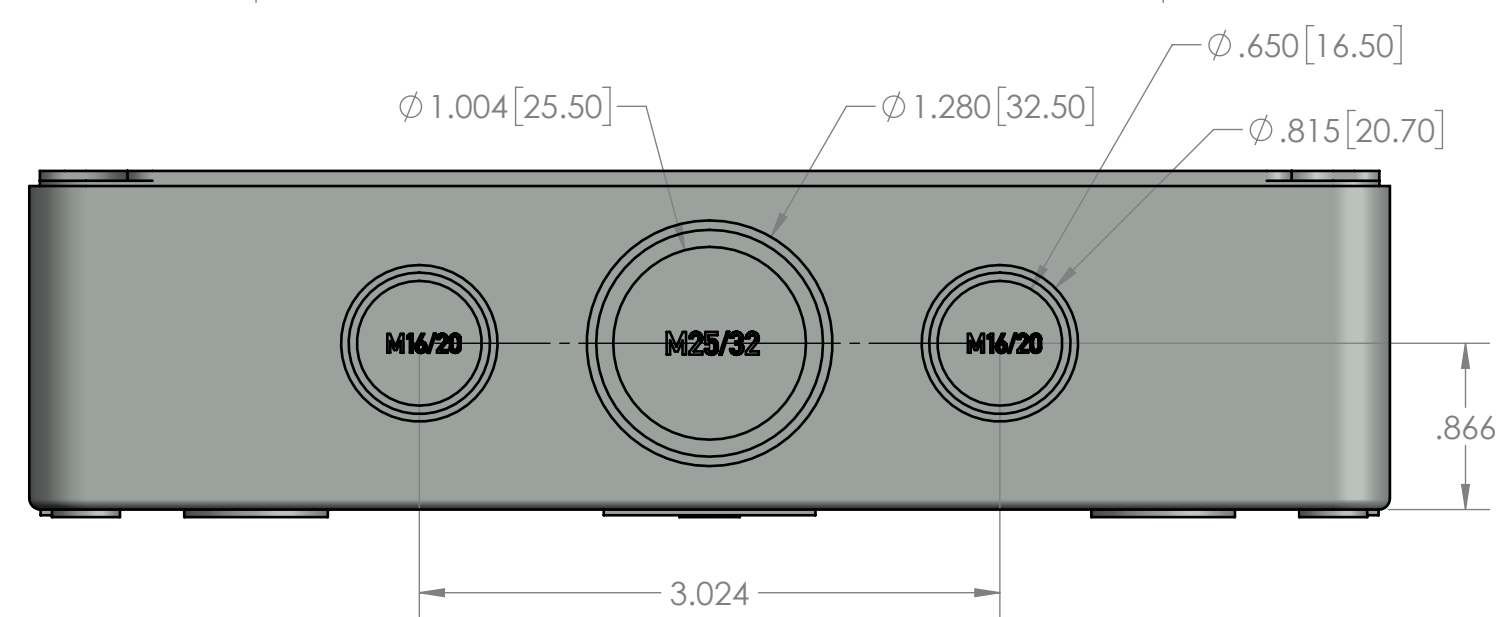
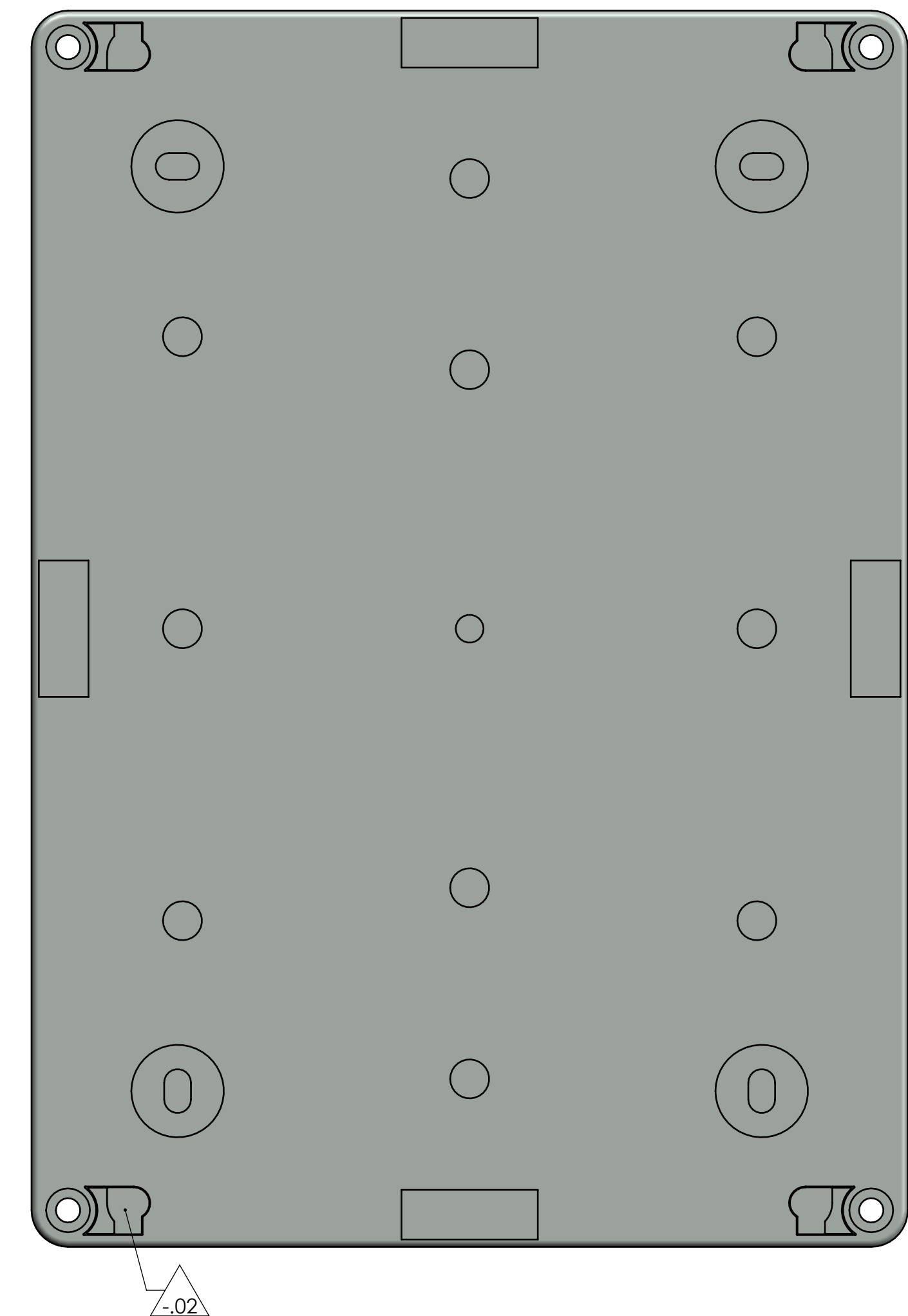
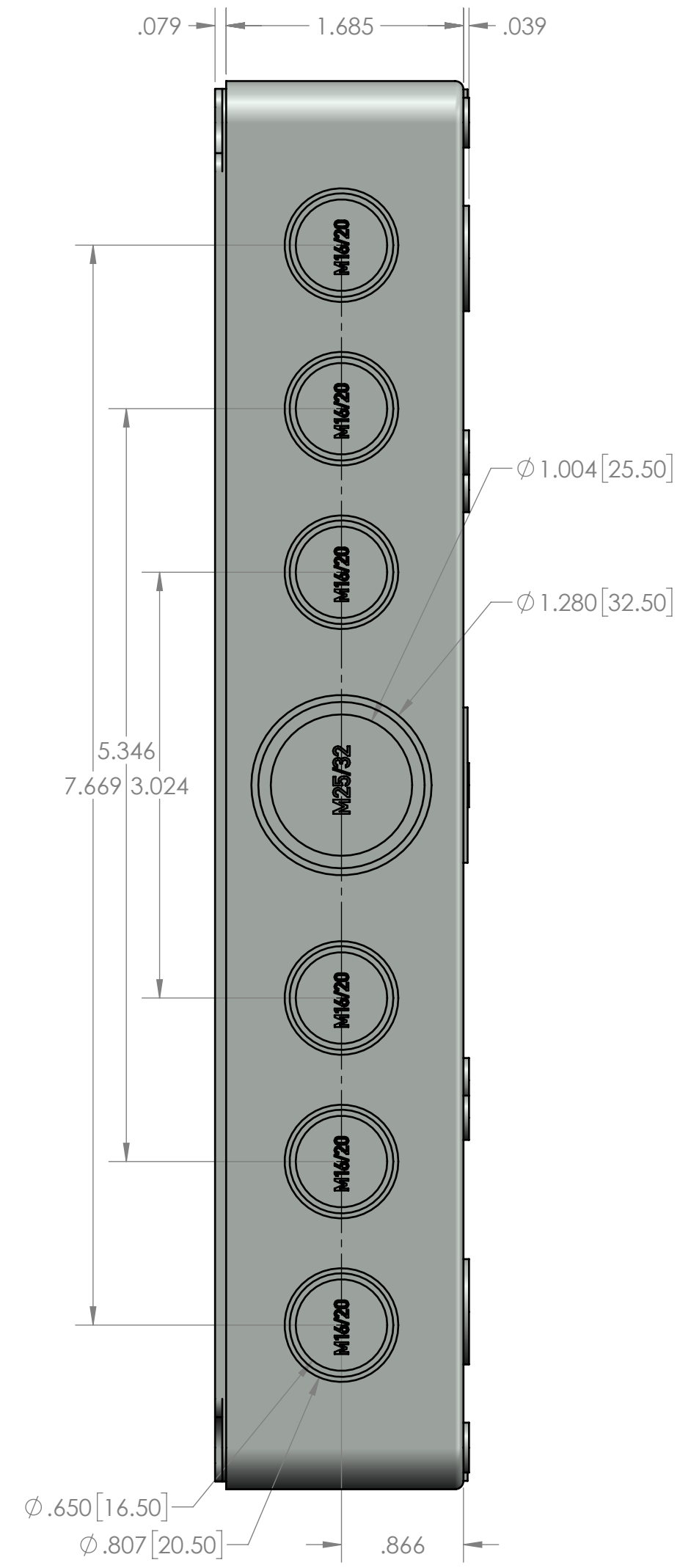
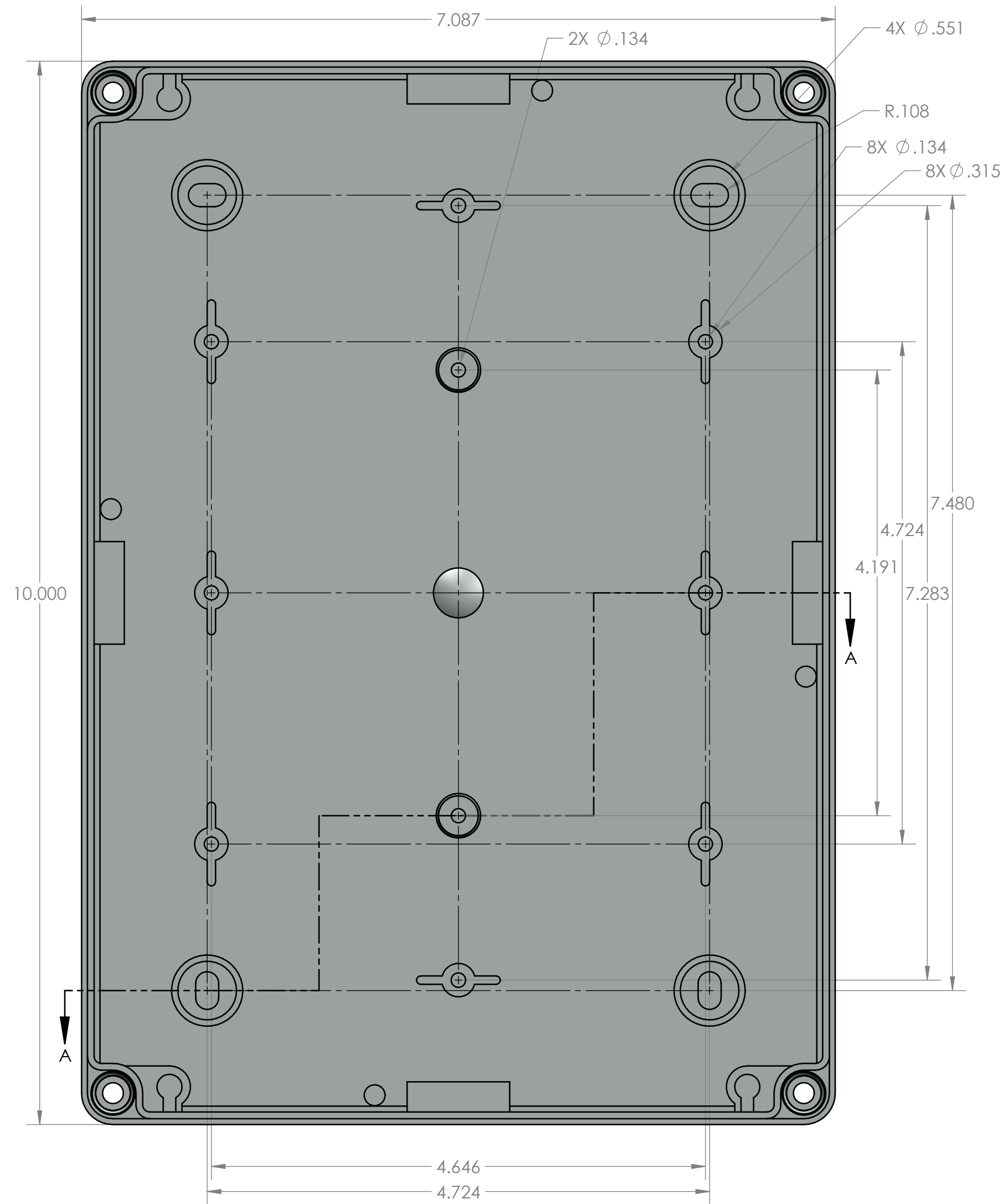
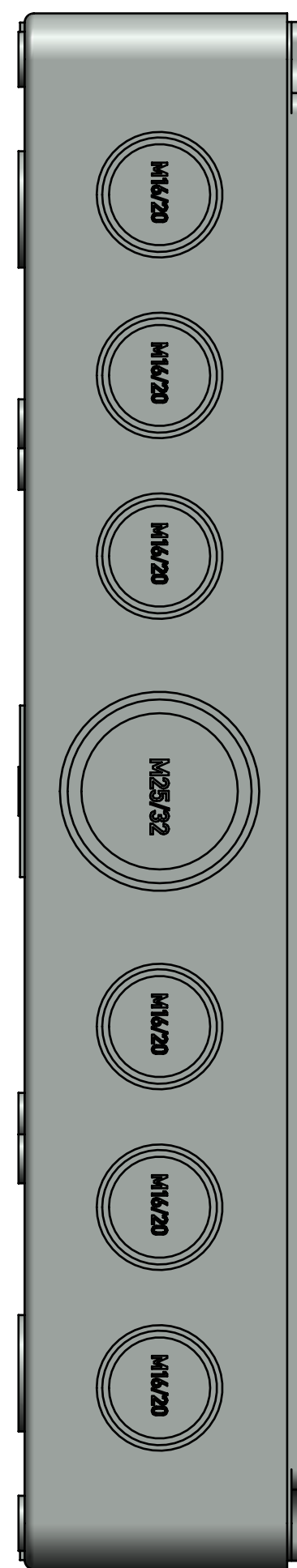
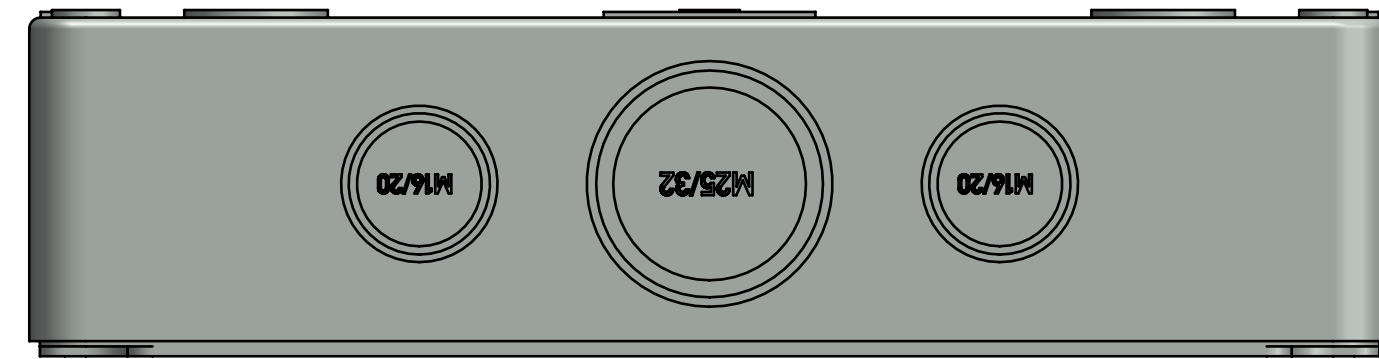

REVISIONS					PART NO.		MATERIAL		FLAME RATING		SIZE		SCALE	
REV.	DESCRIPTION	ZONE	BY	APPR'D	DATE	SK-20B-02	GFR/PC			D	1:1			
-02	ADDED CORES	B3	D.M.F.	D.M.F.	6/16/2020									
-01	ADDED GATE		D.M.F.		6/6/2019									

UNLESS OTHERWISE SPECIFIED:
DIMENSIONS ARE IN INCHES (IN)
TOLERANCES: ANGULAR: ±2°
TWO PLACE DECIMAL: ±.01
THREE PLACE DECIMAL: ±.005
PRINTED GRAPHICS: 1:500
PROPERTY AND CONFIDENTIAL INFORMATION CONTAINED IN THIS DRAWING IS THE SOLE PROPERTY OF POLYCASE. ANY REPRODUCTION IN PART OR AS A WHOLE WITHOUT THE WRITTEN PERMISSION OF POLYCASE IS PROHIBITED.
CAD FILE: SK-20B

1995 CHESTER NEW HAMPSHIRE PARK, CHESTER, NH 03033 U.S.A.
PH: 603-288-1222 FAX: 603-288-1248
WWW.POLYCASE.COM

NAME: D.M.F. DATE: 8/18/2015
DRAWN: B.M.B. CHECKED: 9/2/2015

BASE REV -02 SHEET 1 OF 1

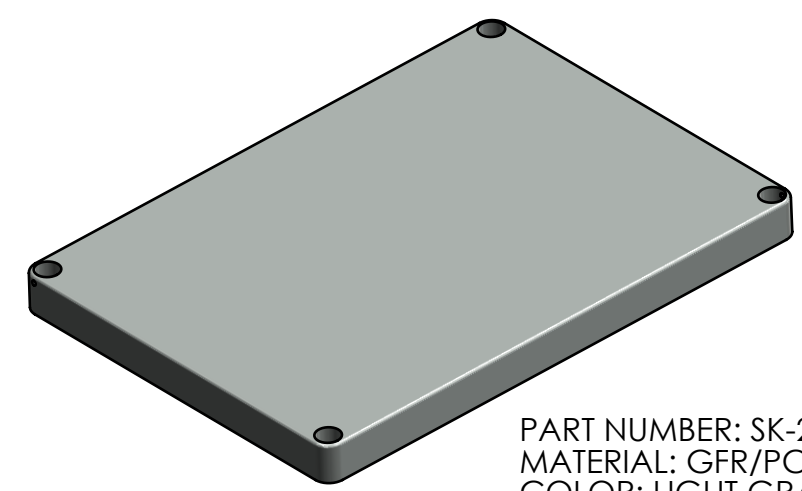
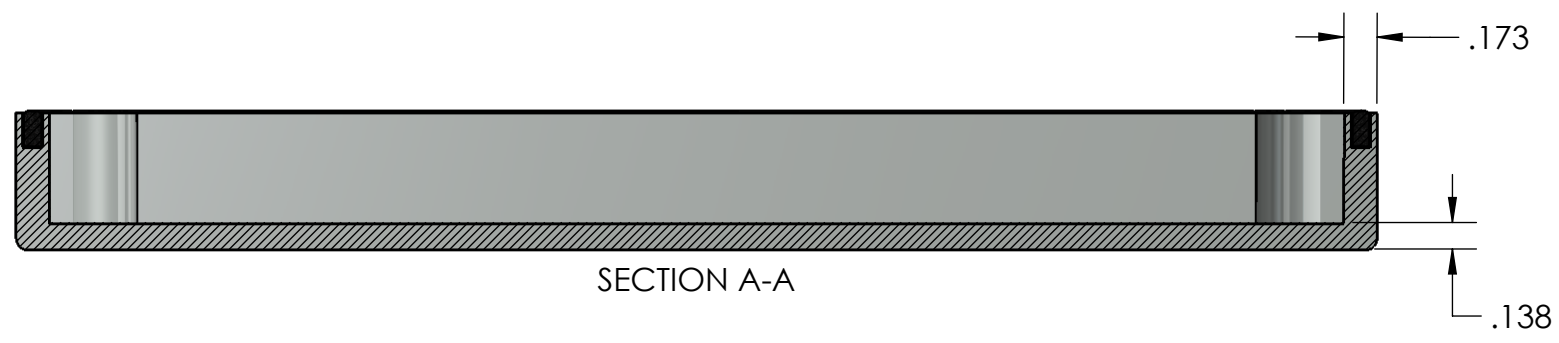

PART NUMBER: SK-20C-02
 MATERIAL: GFR/PC
 COLOR: LIGHT GRAY

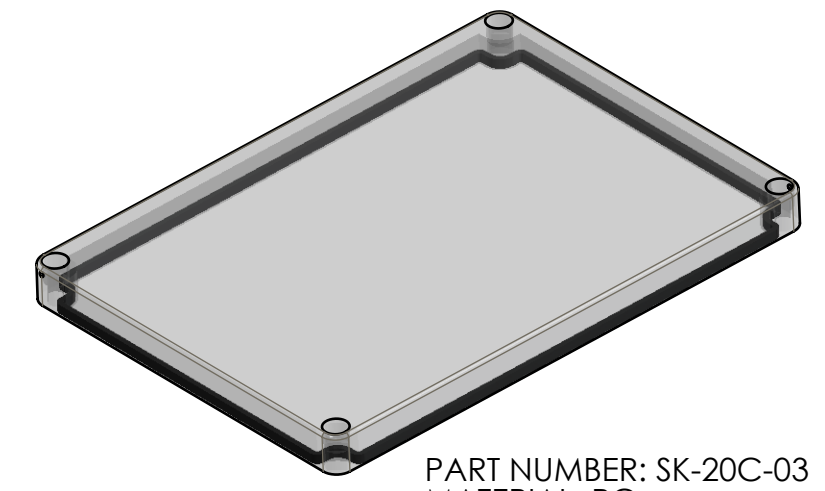

PART NUMBER: SK-20C-03
 MATERIAL: PC
 COLOR: CLEAR

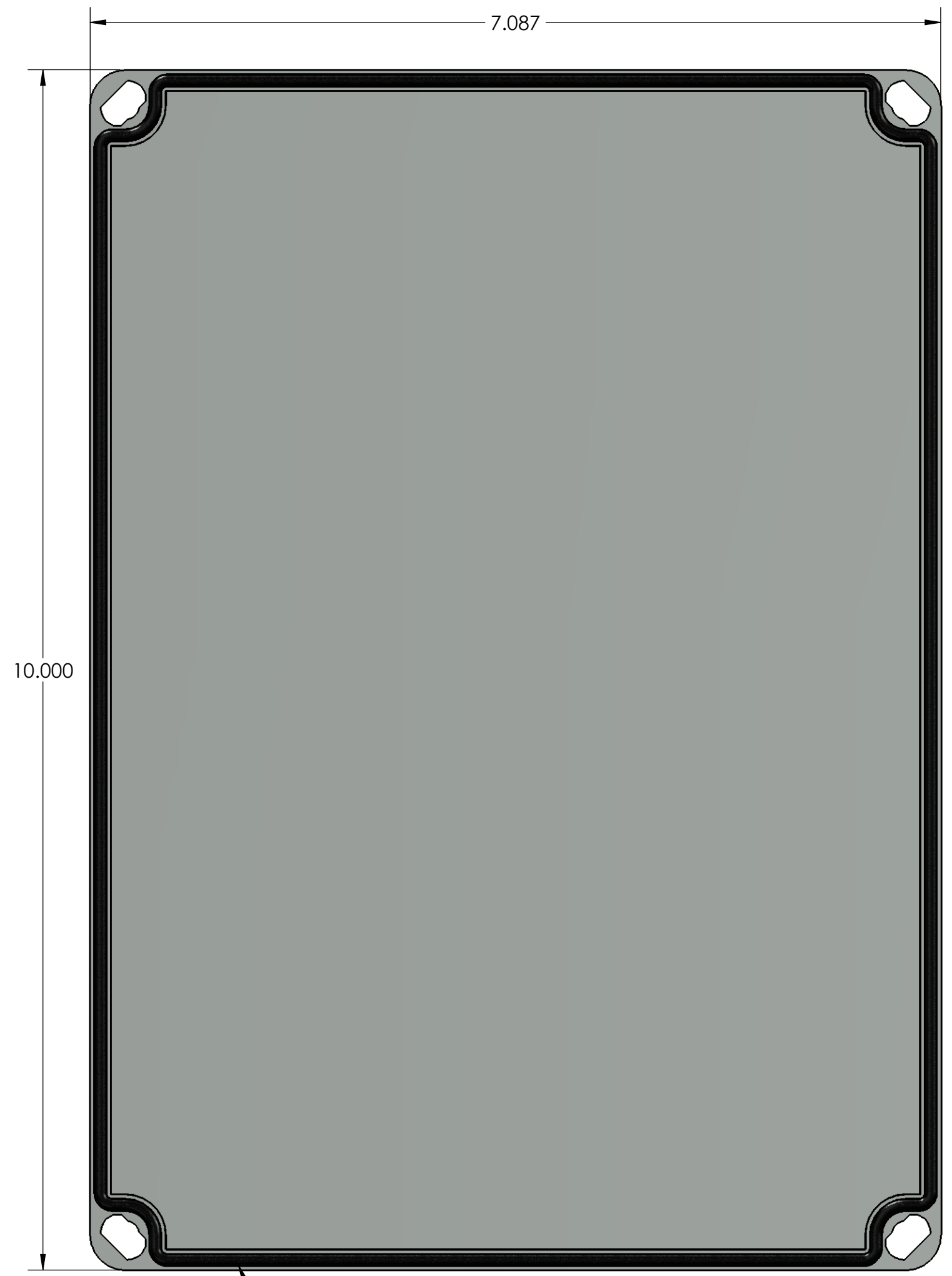
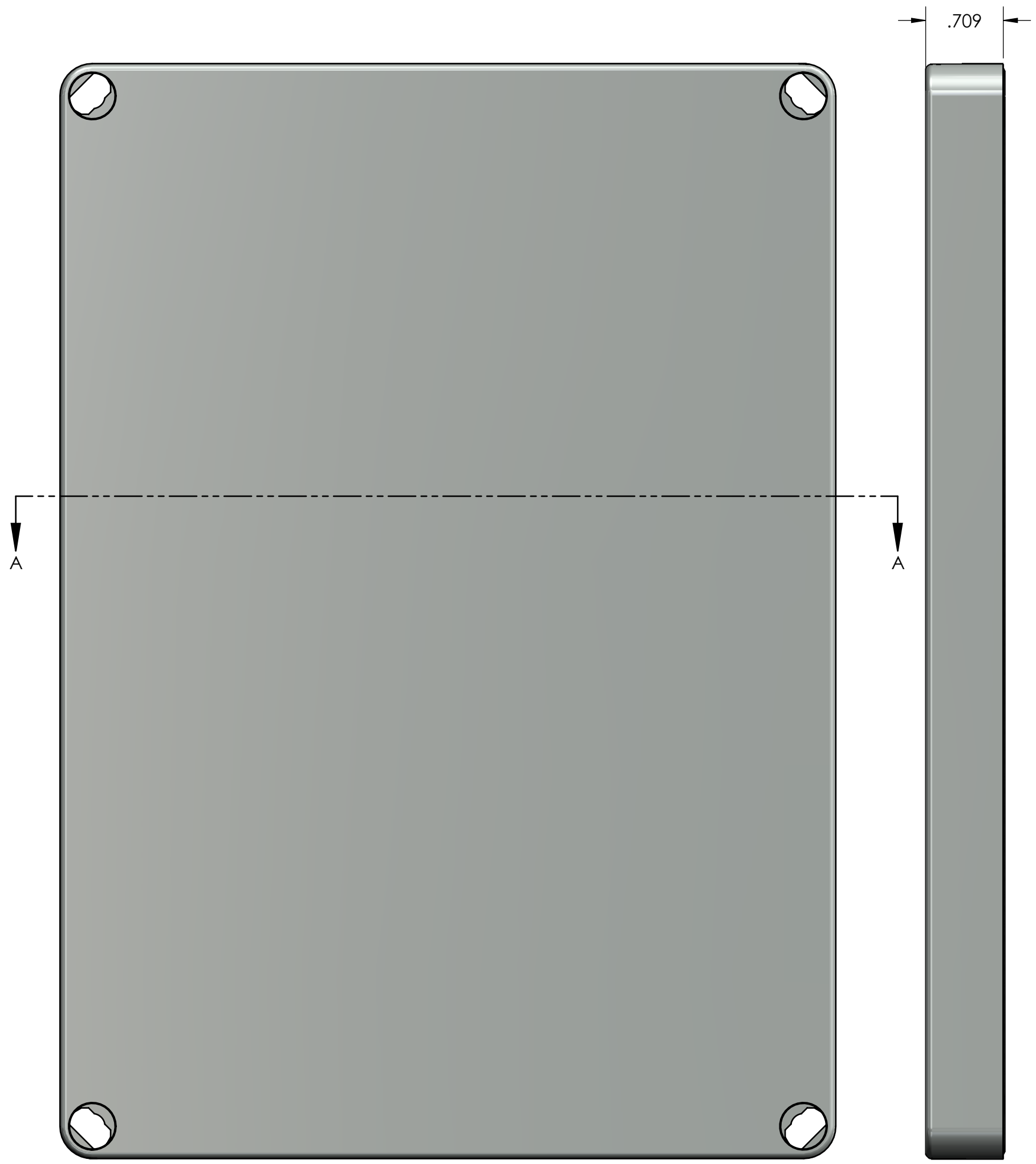

UNLESS OTHERWISE SPECIFIED: DIMENSIONS ARE IN: INCHES[mm] TOLERANCES: ANGULAR: ±2° TWO PLACE DECIMAL: ± THREE PLACE DECIMAL: ± PRINTED GRAPHICS: ±.010		PART NO. SK-20C		 <small>1303 CHESTER RD. PARKWAY AVON, OHIO 44011-1083 U.S.A. PHF: 1-800-248-1233 440-934-0444 FAX: 440-934-0088</small>											
PROPRIETARY AND CONFIDENTIAL THE INFORMATION CONTAINED IN THIS DRAWING IS THE SOLE PROPERTY OF POLYCASE. ANY REPRODUCTION IN PART OR AS A WHOLE WITHOUT THE WRITTEN PERMISSION OF POLYCASE IS PROHIBITED. CAD FILE: SK-20C		MATERIAL -				FLAME RATING -	SIZE C								
REV.	DESCRIPTION	ZONE	BY	APP'D	DATE	<table border="1"> <tr> <td>DRAWN</td> <td>NAME</td> <td>DATE</td> </tr> <tr> <td>CHECKED</td> <td>D.M.F.</td> <td>8/18/2015</td> </tr> <tr> <td></td> <td>B.M.B.</td> <td>9/2/2015</td> </tr> </table>	DRAWN	NAME	DATE	CHECKED	D.M.F.	8/18/2015		B.M.B.	9/2/2015
DRAWN	NAME	DATE													
CHECKED	D.M.F.	8/18/2015													
	B.M.B.	9/2/2015													
<table border="1"> <tr> <td>REVISIONS</td> <td>SCALE: 1:1</td> <td>COVER</td> <td>REV</td> </tr> </table>						REVISIONS	SCALE: 1:1	COVER	REV						
REVISIONS	SCALE: 1:1	COVER	REV												

REV.	DESCRIPTION	ZONE	BY	APP'D	DATE
REVISIONS					