

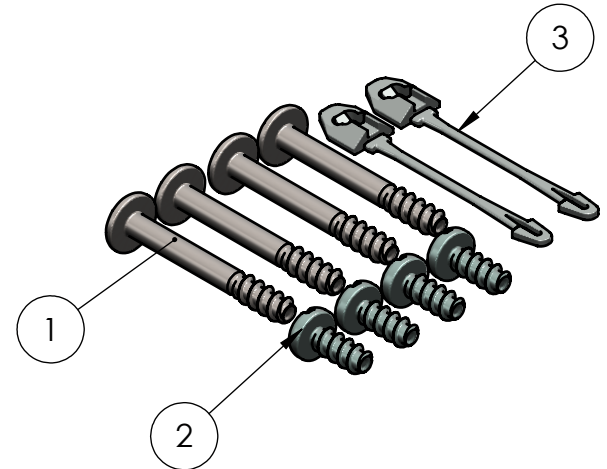

BOM Table

ITEM NO.	PART NUMBER	Rev.	Description	Material	QTY.
1	SCREWS-018	0	M3.85x1.8 SPAX X 29mm LG, PAN HEAD, PHILLIPS	304 SST	4
2	SCREWS-022	0	M3.85x1.8 SPAX X 9mm LG, PAN HEAD, PHILLIPS	QSt36-3	4
3	SG-98S	0	RETAINER STRAP	PA6	2

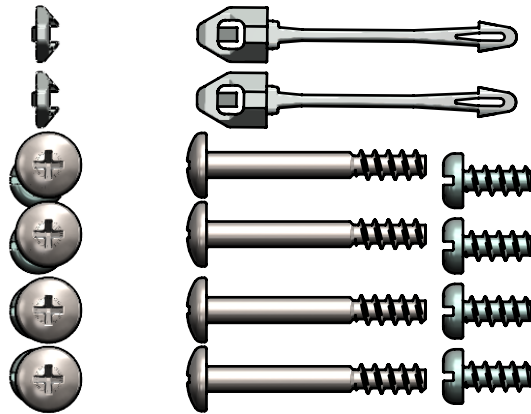

REV.	DESCRIPTION	ZONE	BY	APPR'D	DATE
-.01	UPDATED CONFIG PROPERTIES		D.M.F.		9/12/2017
REVISIONS					

UNLESS OTHERWISE SPECIFIED: DIMENSIONS ARE IN: INCHES[mm] TOLERANCES: ANGULAR: ±2° TWO PLACE DECIMAL: ±.010 THREE PLACE DECIMAL: ±.005 PRINTED GRAPHICS: ±.010		PART NO. SG-KIT-01		 <small>1305 CHESTER IND. PARKWAY AVON, OHIO 44011-1083 U.S.A. PH#: 1-800-248-1233, 440-934-0444 FAX#: 440-934-0088</small>	
PROPRIETARY AND CONFIDENTIAL THE INFORMATION CONTAINED IN THIS DRAWING IS THE SOLE PROPERTY OF POLYCASE. ANY REPRODUCTION IN PART OR AS A WHOLE WITHOUT THE WRITTEN PERMISSION OF POLYCASE IS PROHIBITED. CAD FILE: SG-KIT-01		MATERIAL			
FLAME RATING		SIZE A		HARDWARE KIT	
DRAWN CHECKED		NAME D.M.F. B.M.B.		DATE 9/4/2015 9/8/2015	
SCALE: 1:1				REV 0 SHEET 1 OF 1	

5

4

3

2

1

D
C
B
A