

BOM Table						
ITEM NO.	PART NUMBER	Rev.	Description	Material	Color	QTY.
1	SG-17B-02	-	BASE	PC	LIGHT GRAY	1
2	SG-10C-02	-.01	COVER	PC	LIGHT GRAY	1
3	SG-KIT-01	-	HARDWARE KIT			1
3.1	SCREWS-18	-	M3.85x1.8 SPAX X 29mm LG, PAN HEAD, PHILLIPS	304 SST		4
3.2	SCREWS-022	-.01	M3.85x1.8 SPAX X 9mm LG, PAN HEAD, PHILLIPS	QS136-3		4
3.3	SG-98S	-.01	RETAINER STRAP	PA6	GRAY	2

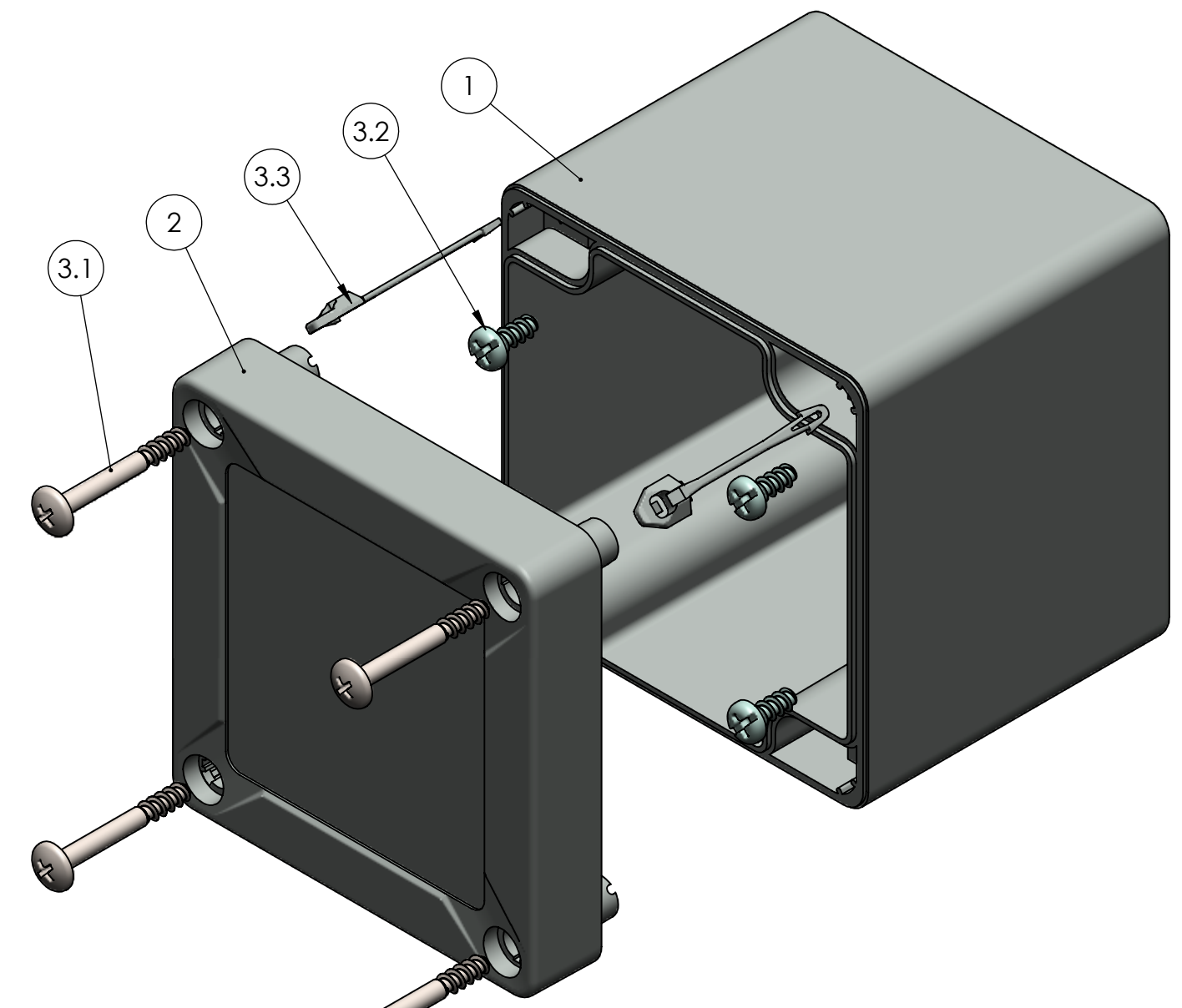

PART NUMBER: SG-17-02
 FLAME RATING: 5VA per UL50/UL746C

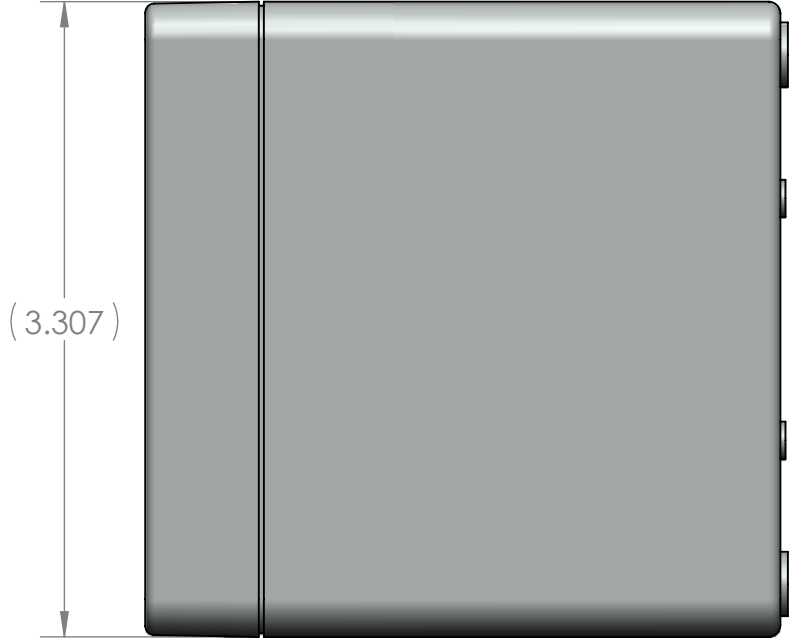
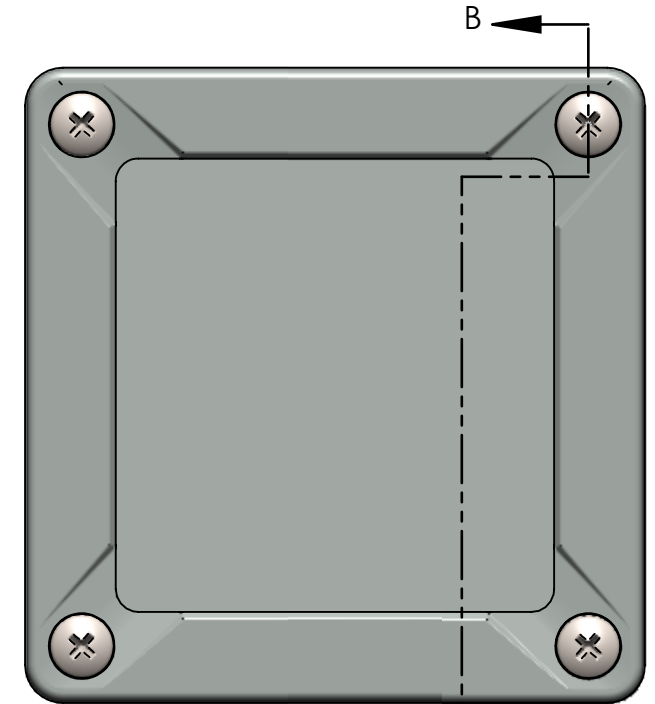
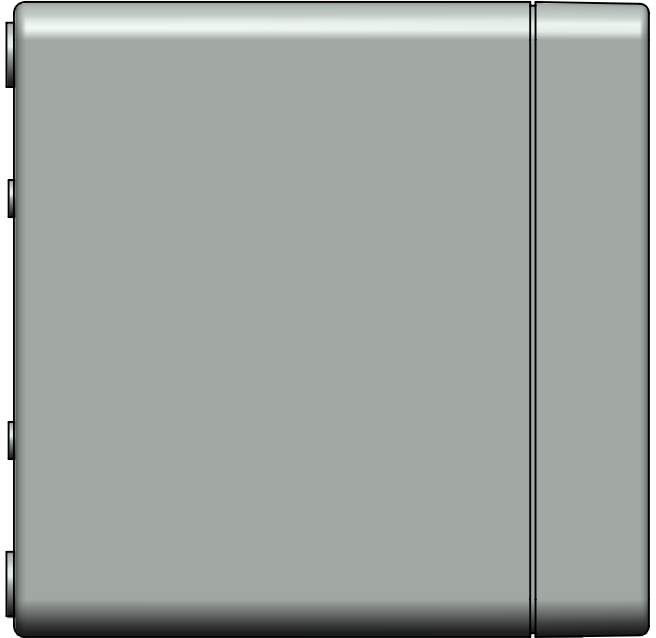
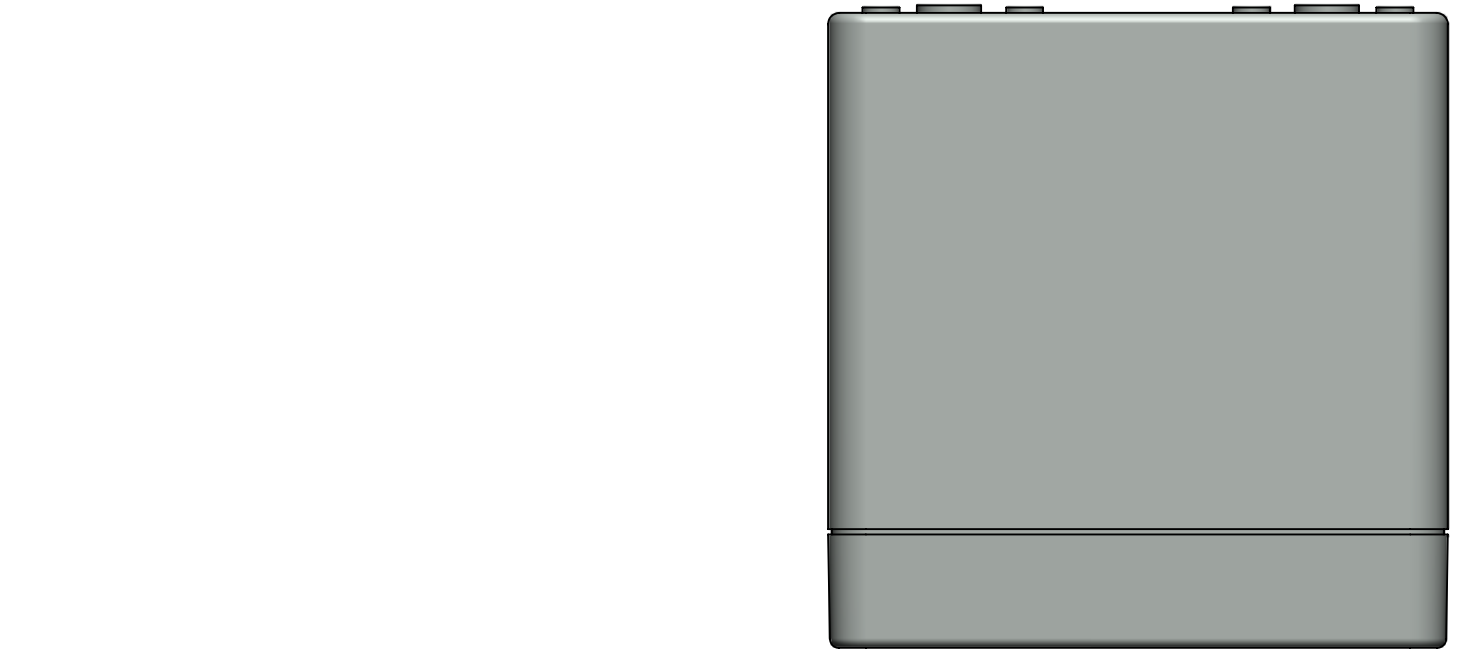
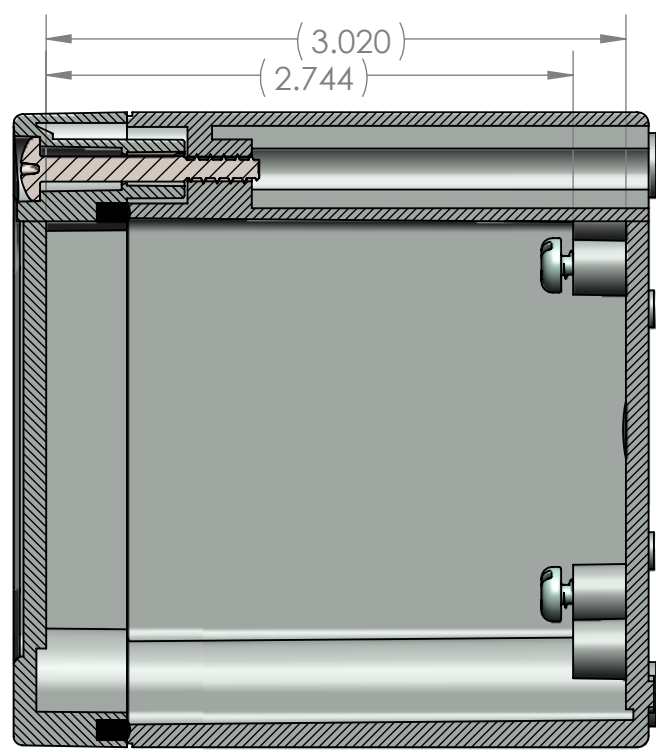
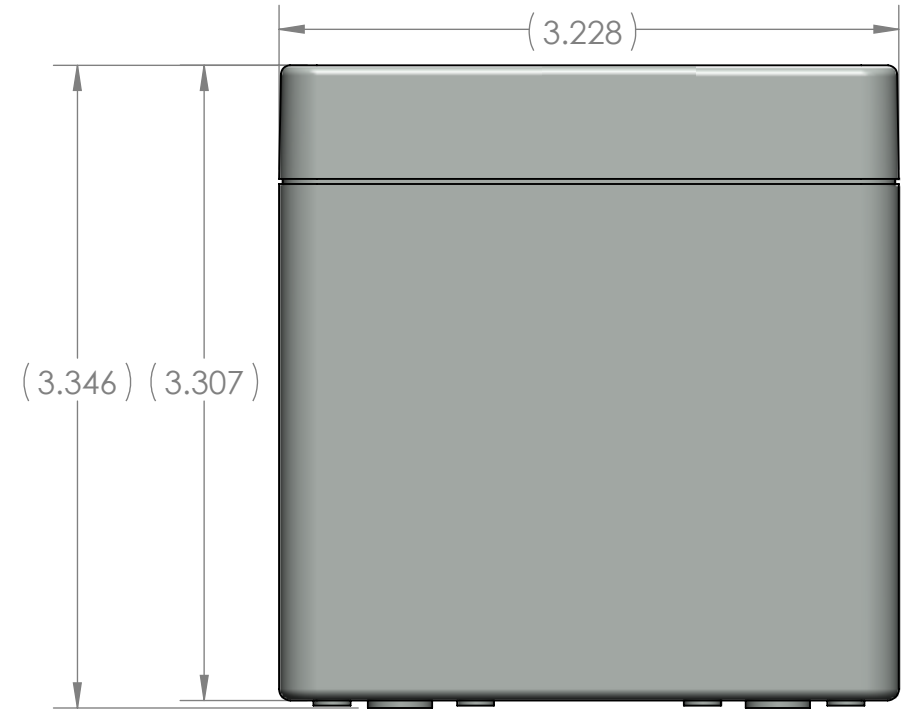

SECTION B-B

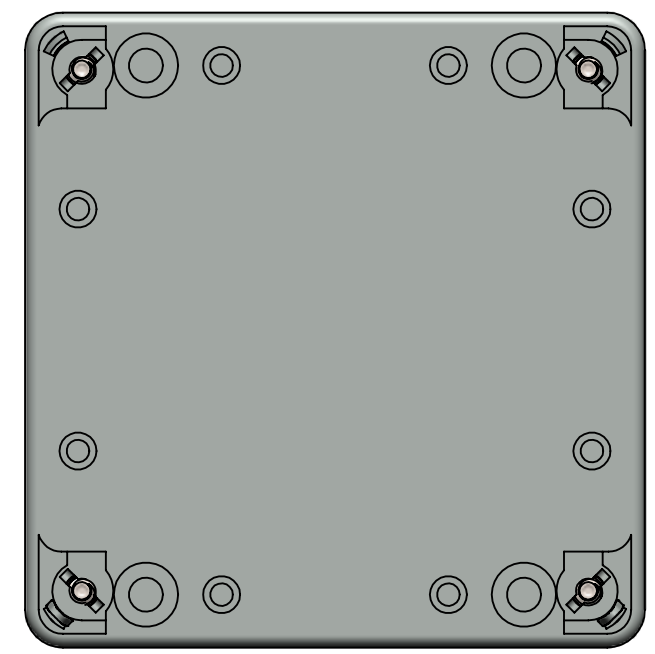

UNLESS OTHERWISE SPECIFIED: DIMENSIONS ARE IN: INCHES[mm] TOLERANCES: ANGULAR: ±2° TWO PLACE DECIMAL: ± THREE PLACE DECIMAL: ± PRINTED GRAPHICS: ±0.10		PART NO. SEE BOM		 <small>1305 CHESTER RD. PARKWAY AVON, OHIO 44011-1083 U.S.A. PH: 1-800-248-1233 440-934-0444 FAX: 440-934-0088</small>	
PROPRIETARY AND CONFIDENTIAL THE INFORMATION CONTAINED IN THIS DRAWING IS THE SOLE PROPERTY OF POLYCASE. ANY REPRODUCTION IN PART OR AS A WHOLE WITHOUT THE WRITTEN PERMISSION OF POLYCASE IS PROHIBITED. CAD FILE: SG-17		MATERIAL SEE BOM			
REV.		DESCRIPTION		FLAME RATING SEE BOM	
REVISIONS		ZONE BY APPR'D DATE		NAME DATE D.M.F. 3/7/2016 CHECKED 9/8/2015	
				SIZE C SCALE: 1:1	
				REV SHEET 1 OF 2	

REV.	DESCRIPTION	ZONE	BY	APPR'D	DATE

8 7 6 5 4 3 2 1

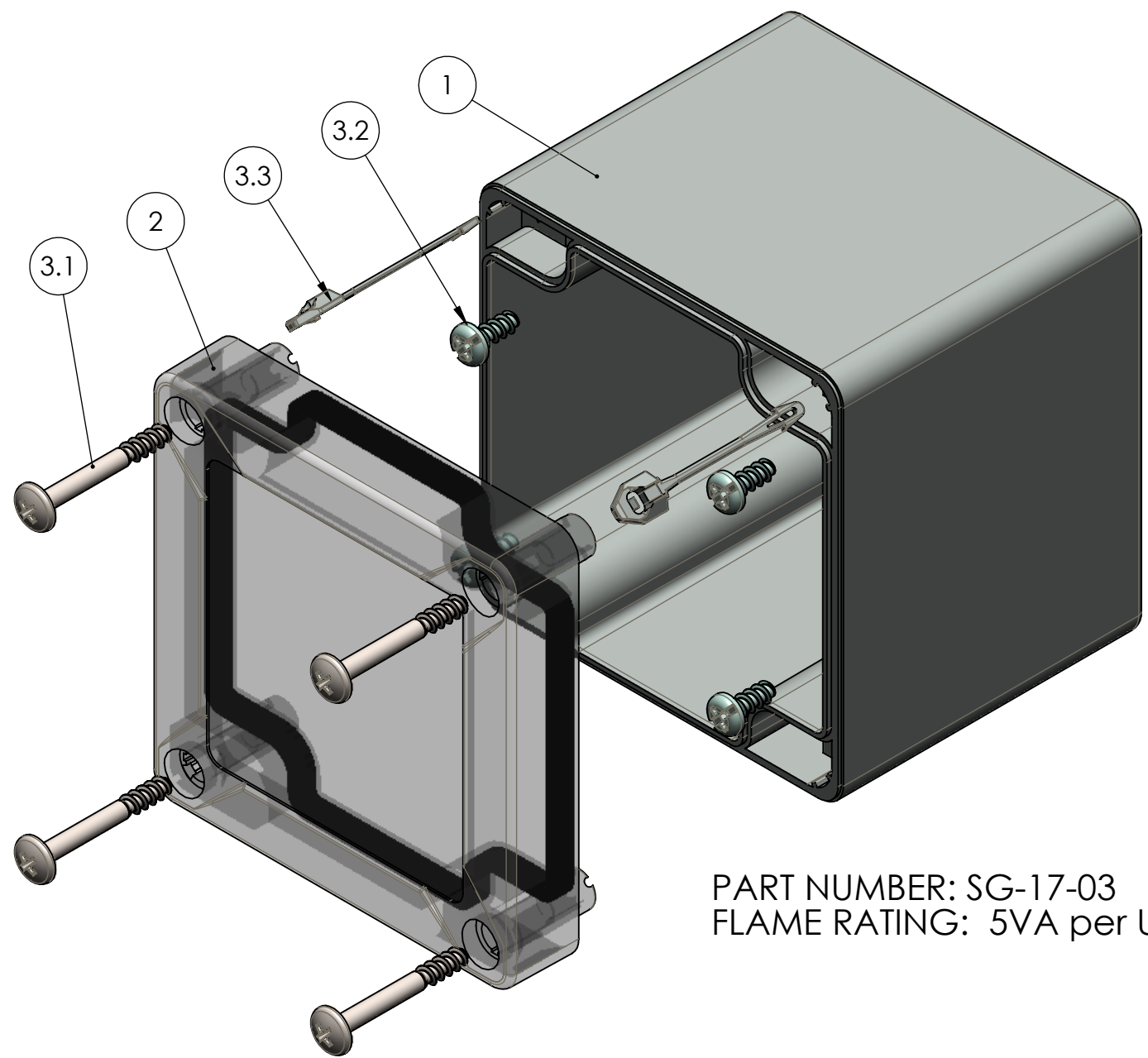

BOM Table						
ITEM NO.	PART NUMBER	Rev.	Description	Material	Color	QTY.
1	SG-17B-02	-	BASE	PC	LIGHT GRAY	1
2	SG-10C-03	-.01	COVER	PC	CLEAR	1
3	SG-KIT-01	-	HARDWARE KIT			1
3.1	SCREWS-18	-	M3.85x1.8 SPAX X 29mm LG, PAN HEAD, PHILLIPS	304 SST		4
3.2	SCREWS-022	-.01	M3.85x1.8 SPAX X 9mm LG, PAN HEAD, PHILLIPS	QSt36-3		4
3.3	SG-98S	-.01	RETAINER STRAP	PA6	GRAY	2

D
C
B
A



PART NUMBER: SG-17-03
 FLAME RATING: 5VA per UL50/UL746C

8 7 6 5 4 3 2 1

<small>UNLESS OTHERWISE SPECIFIED: DIMENSIONS ARE IN: INCHES[mm] TOLERANCES: ANGULAR: ±2° TWO PLACE DECIMAL: ± THREE PLACE DECIMAL: ± PRINTED GRAPHICS: ±.010</small>	PART NO. SEE BOM		 <small>1305 CHESTER IND. PARKWAY AVON, OHIO 44011-1083 U.S.A. PH#: 1-800-248-1233, 440-934-0444 FAX#: 440-934-0088</small>	
	MATERIAL SEE BOM			
	FLAME RATING SEE BOM		SIZE B	REV -
	<small>PROPRIETARY AND CONFIDENTIAL THE INFORMATION CONTAINED IN THIS DRAWING IS THE SOLE PROPERTY OF POLYCASE. ANY REPRODUCTION IN PART OR AS A WHOLE WITHOUT THE WRITTEN PERMISSION OF POLYCASE IS PROHIBITED. CAD FILE: SG-17</small>	<small>DRAWN D.M.F.</small>	<small>DATE 3/7/2016</small>	<small>SCALE: 1:1</small>
<small>CHECKED</small>	<small>-</small>	<small>9/8/2015</small>		<small>SHEET 2 OF 2</small>

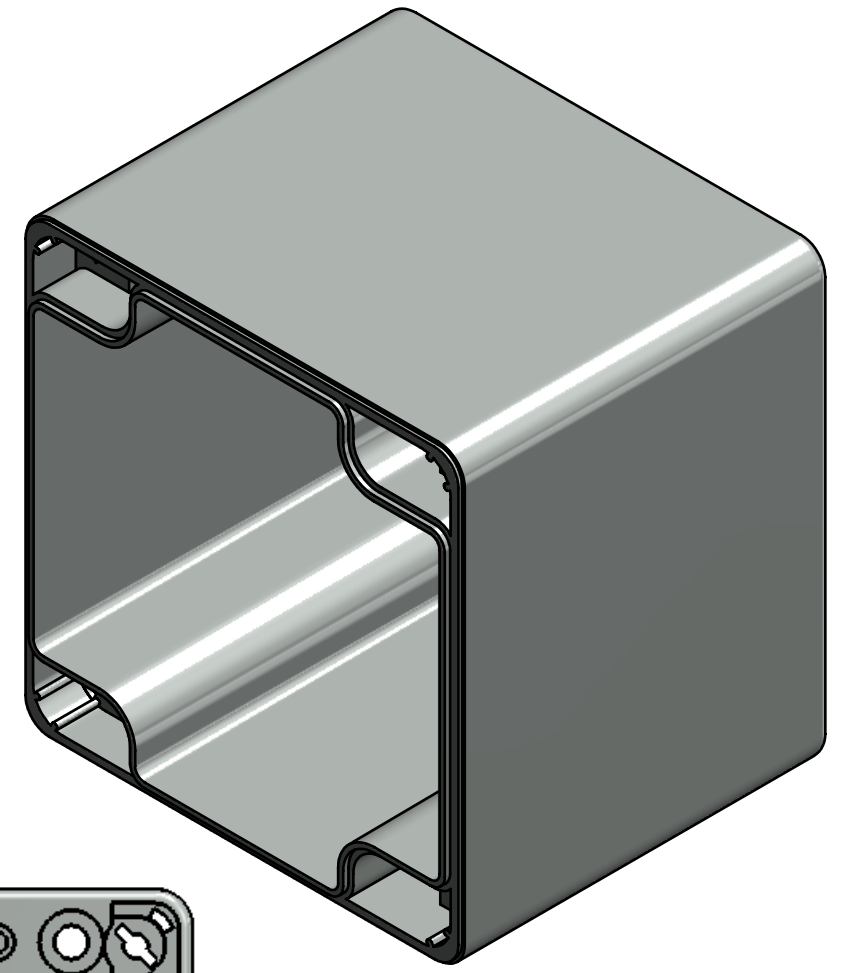
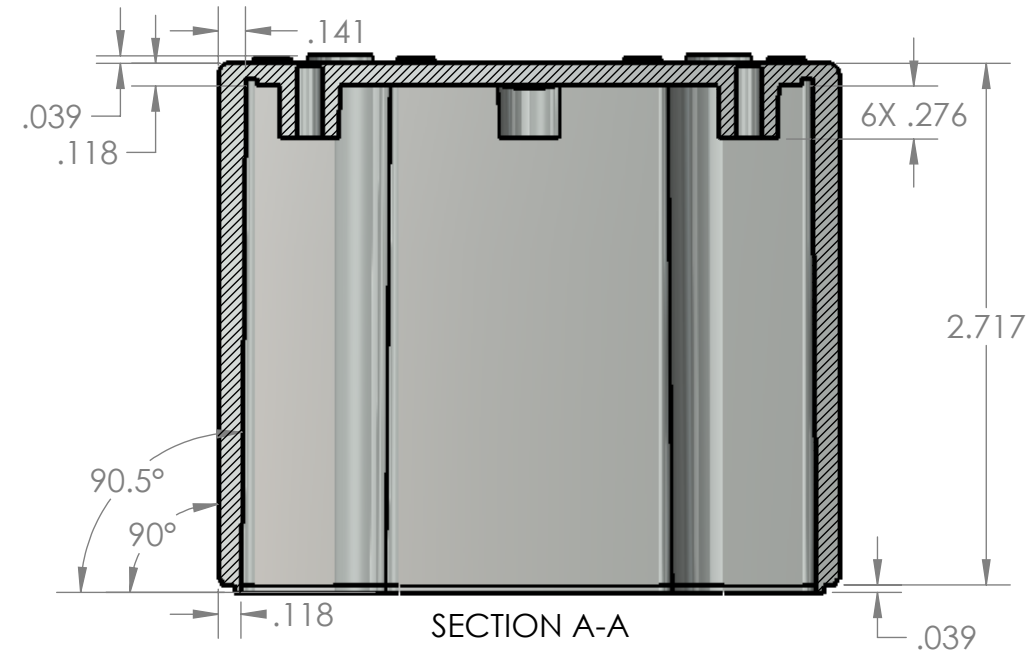

PART NUMBER: SG-17B-02
 COLOR: LIGHT GRAY

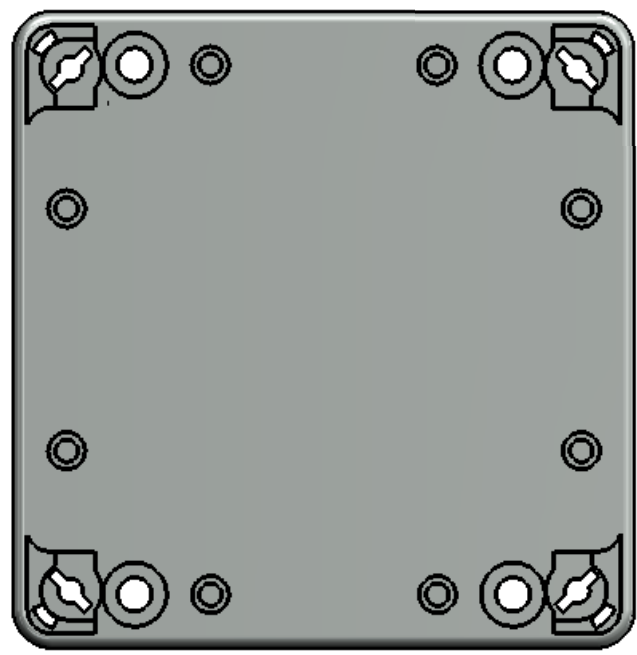
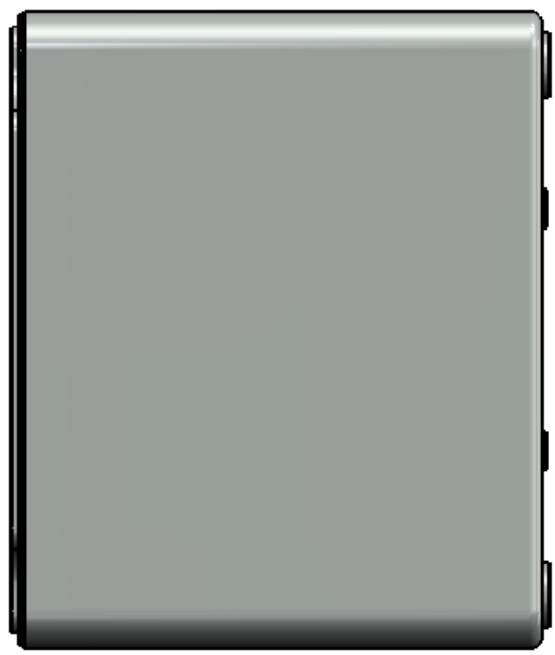
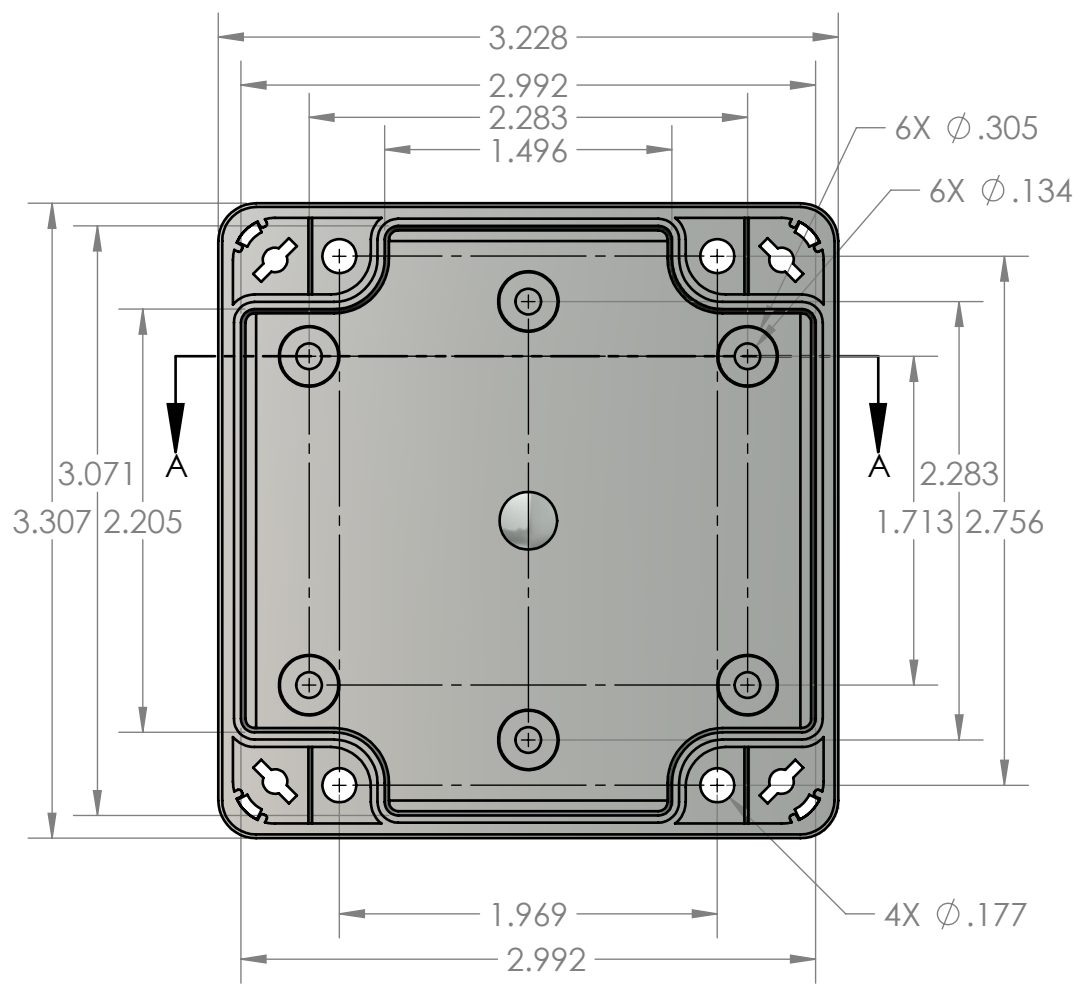

UNLESS OTHERWISE SPECIFIED:
 DIMENSIONS ARE IN: INCHES [mm]
 TOLERANCES: ANGULAR: ±2°
 TWO PLACE DECIMAL: ±
 THREE PLACE DECIMAL: ±
 PRINTED GRAPHICS: ±.010

PROPRIETARY AND CONFIDENTIAL
 THE INFORMATION CONTAINED IN THIS
 DRAWING IS THE SOLE PROPERTY OF
 POLYCASE. ANY REPRODUCTION IN PART
 OR AS A WHOLE WITHOUT THE WRITTEN
 PERMISSION OF POLYCASE IS PROHIBITED.
 CAD FILE: SG-17B

PART NO. SG-17B-02		
MATERIAL PC		
FLAME RATING -		
DRAWN	NAME	DATE
CHECKED	B.M.B.	3/10/2016

polycase
 1305 CHESTER IND. PARKWAY AVON, OHIO 44011-1083 U.S.A.
 PH#: 1-800-248-1233, 440-934-0444 FAX#: 440-934-0088

SIZE B	BASE	REV -
SCALE: 1:1	SHEET 1 OF 1	

REV.	DESCRIPTION	ZONE	BY	APPR'D	DATE
REVISIONS					

8 7 6 5 4 3 2 1

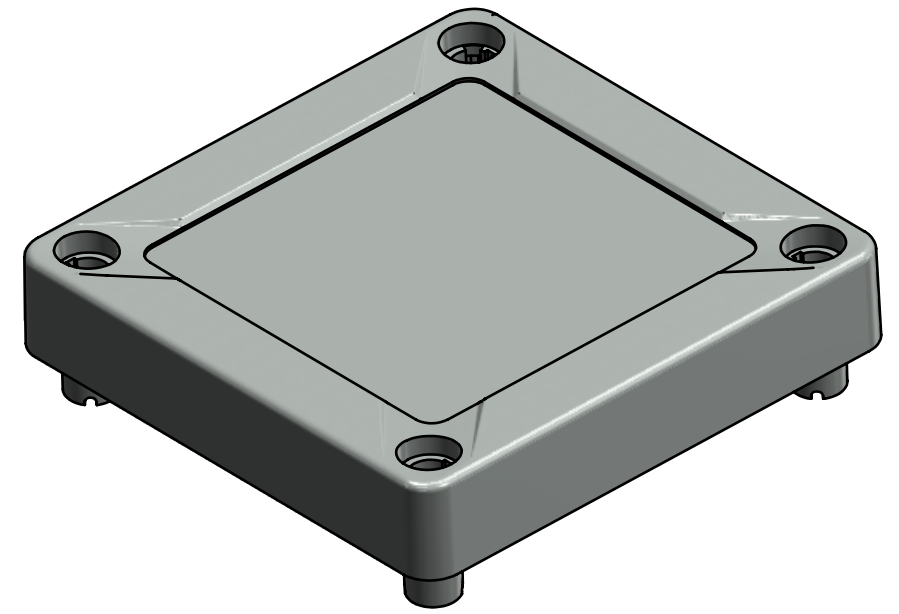
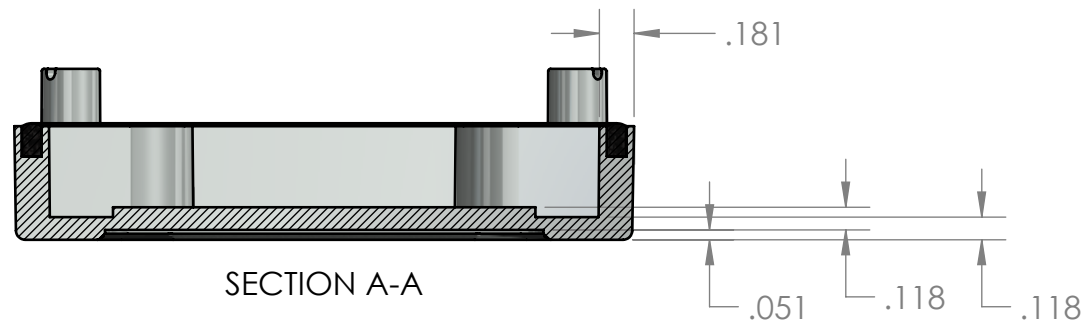

PART NUMBER: SG-10C-02
COLOR: LIGHT GRAY

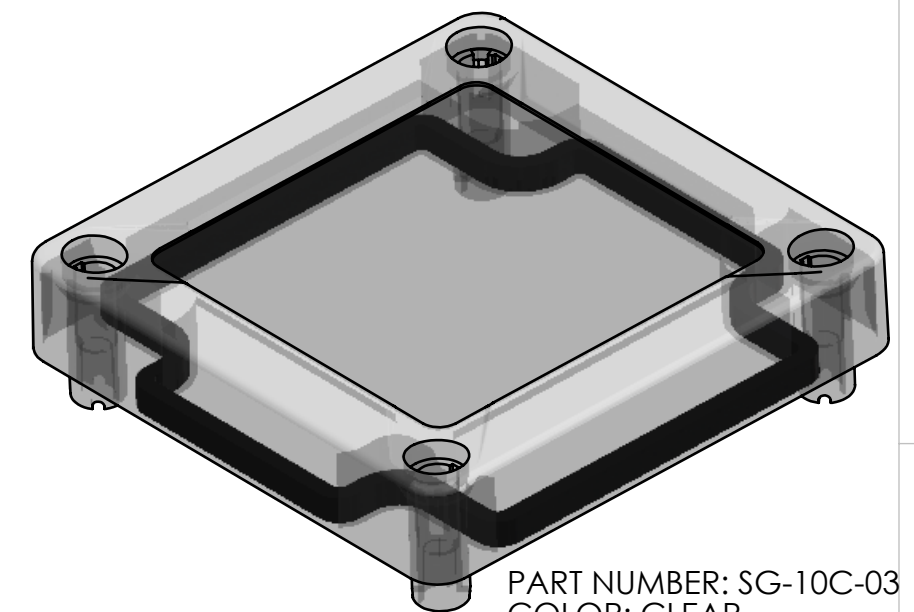
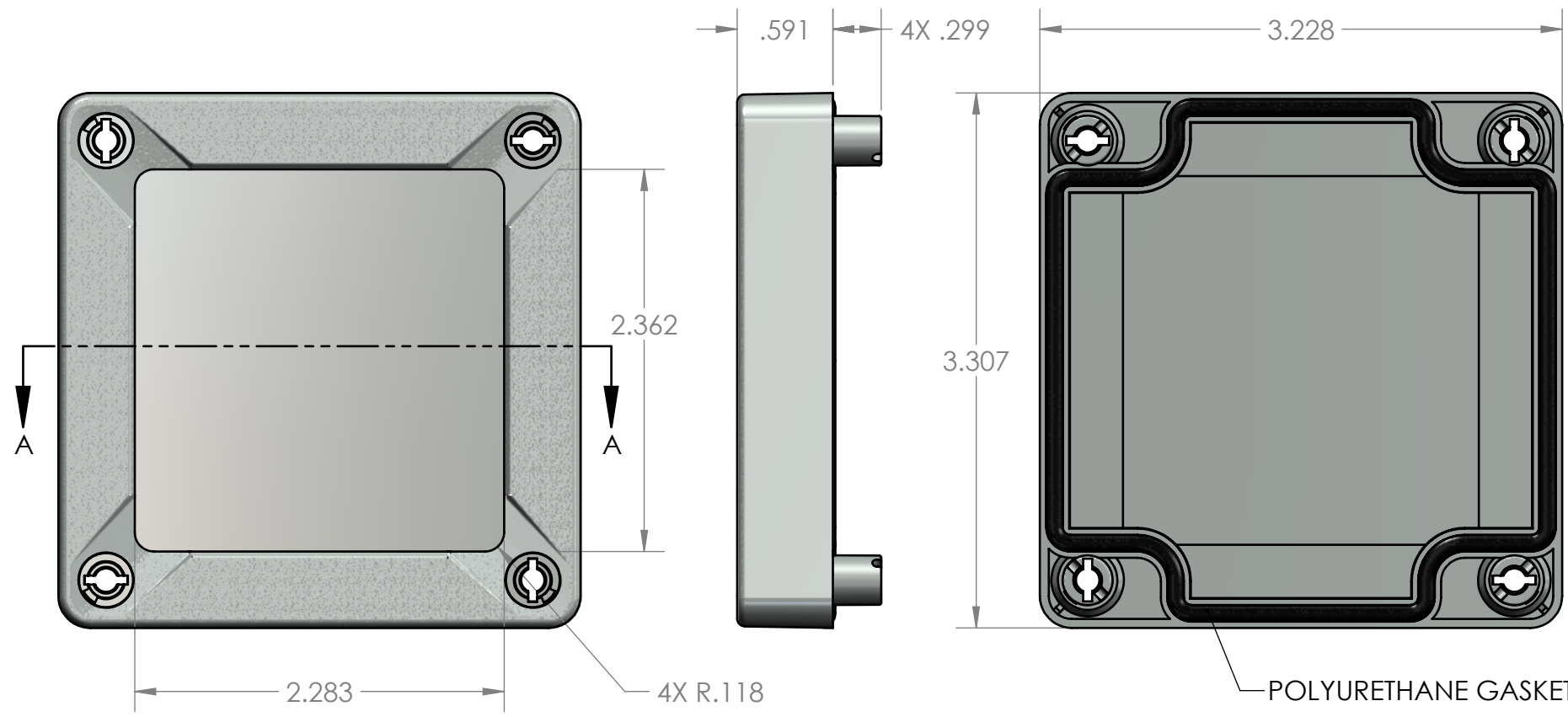

PART NUMBER: SG-10C-03
COLOR: CLEAR

UNLESS OTHERWISE SPECIFIED: DIMENSIONS ARE IN: INCHES [mm] TOLERANCES: ANGULAR: ±2° TWO PLACE DECIMAL: ± THREE PLACE DECIMAL: ± PRINTED GRAPHICS: ±.010	PART NO.		 <small>1305 CHESTER IND. PARKWAY AVON, OHIO 44011-1083 U.S.A. PH#: 1-800-248-1233, 440-934-0444 FAX#: 440-934-0088</small>									
	SG-10C											
	MATERIAL											
	PC											
PROPRIETARY AND CONFIDENTIAL THE INFORMATION CONTAINED IN THIS DRAWING IS THE SOLE PROPERTY OF POLYCASE. ANY REPRODUCTION IN PART OR AS A WHOLE WITHOUT THE WRITTEN PERMISSION OF POLYCASE IS PROHIBITED. CAD FILE: SG-10C	FLAME RATING	SIZE	REV -.01									
		B										
	<table border="1"> <thead> <tr> <th></th> <th>NAME</th> <th>DATE</th> </tr> </thead> <tbody> <tr> <td>DRAWN</td> <td>D.M.F.</td> <td>8/18/2015</td> </tr> <tr> <td>CHECKED</td> <td>B.M.B.</td> <td>9/2/2015</td> </tr> </tbody> </table>		NAME	DATE	DRAWN	D.M.F.	8/18/2015	CHECKED	B.M.B.	9/2/2015	SCALE: 1:1	SHEET 1 OF 1
	NAME	DATE										
DRAWN	D.M.F.	8/18/2015										
CHECKED	B.M.B.	9/2/2015										

8 7 6 5 4 3 2 1