

ITEM NO.	PART NUMBER	DESCRIPTION	Material	QTY.
1	AN-09-P	ALUMINUM PANEL	ALUMINUM	1
2	SCREWS-003-4	SCREW PACK		1
2.1	SCREWS-003	M3.5x0.6 X 6MM LG THREAD FORMING PHMS	STEEL	4

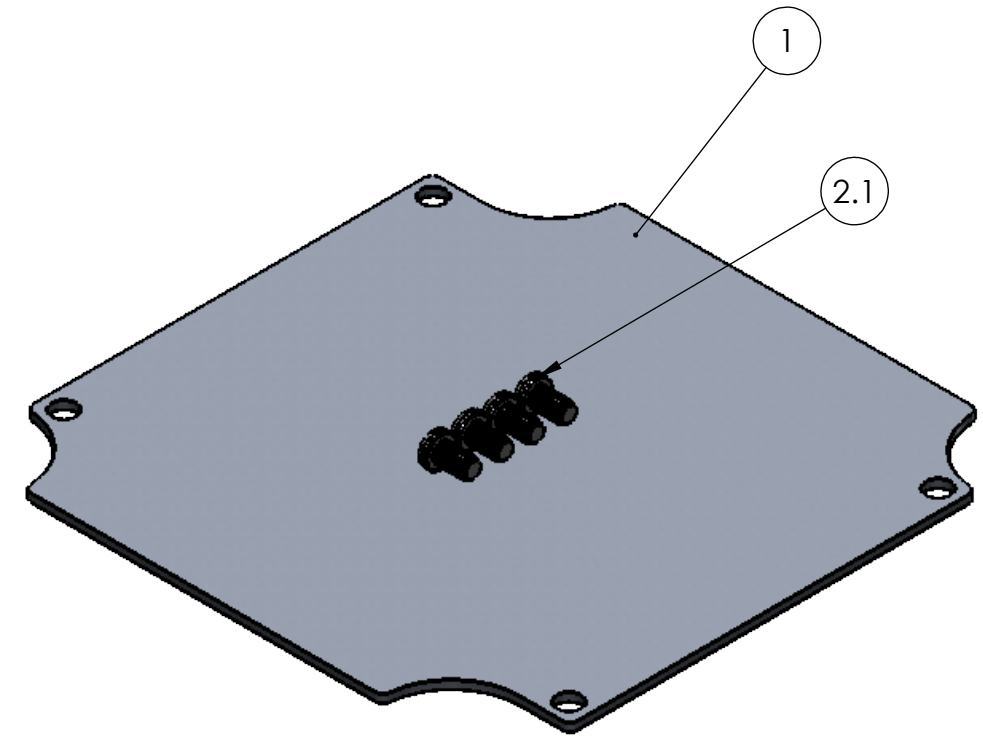
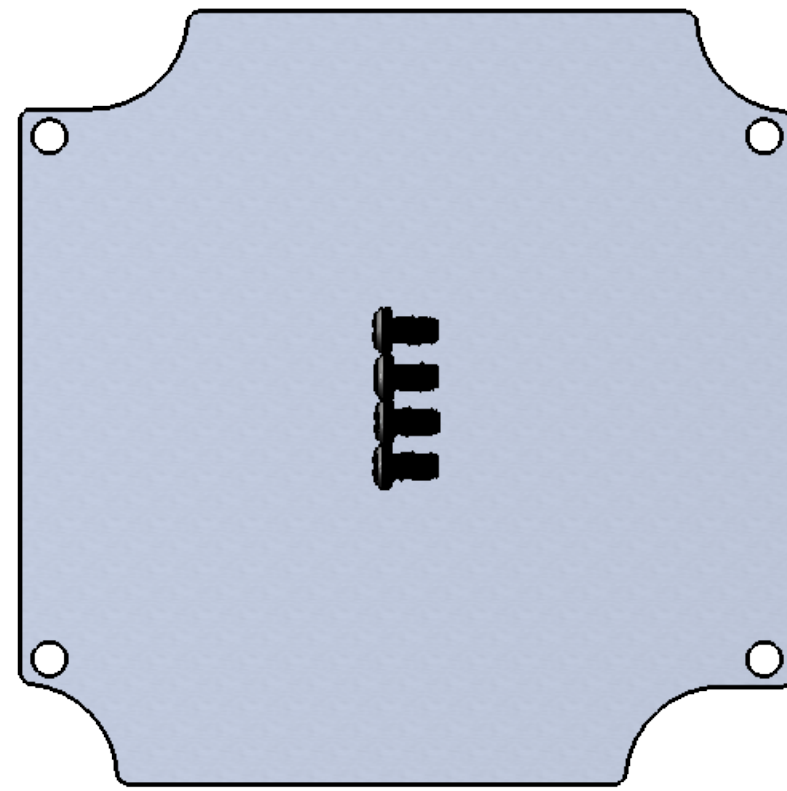

UNLESS OTHERWISE SPECIFIED:
 DIMENSIONS ARE IN: INCHES[mm]
 TOLERANCES: ANGULAR: ±2°
 TWO PLACE DECIMAL: ±.010
 THREE PLACE DECIMAL: ±.005
 PRINTED GRAPHICS: ±.010

PROPRIETARY AND CONFIDENTIAL
 THE INFORMATION CONTAINED IN THIS
 DRAWING IS THE SOLE PROPERTY OF
 POLYCASE. ANY REPRODUCTION IN PART
 OR AS A WHOLE WITHOUT THE WRITTEN
 PERMISSION OF POLYCASE IS PROHIBITED.
 CAD FILE: AN-09K

PART NO.
 AN-09K
 MATERIAL

FLAME RATING

SIZE
 B

polycase
 1305 CHESTER IND. PARKWAY AVON, OHIO 44011-1083 U.S.A.
 PH#: 1-800-248-1233, 440-934-0444 FAX#: 440-934-0088

MOUNTING PANEL KIT

REV

-

	NAME	DATE
DRAWN	D.M.F.	1/4/2017
CHECKED	C.C.B.	1/6/2017

SCALE: 1:1



SHEET 1 OF 1

REV.	DESCRIPTION	ZONE	BY	APPR'D	DATE
	REVISIONS				

8 7 6 5 4 3 2 1

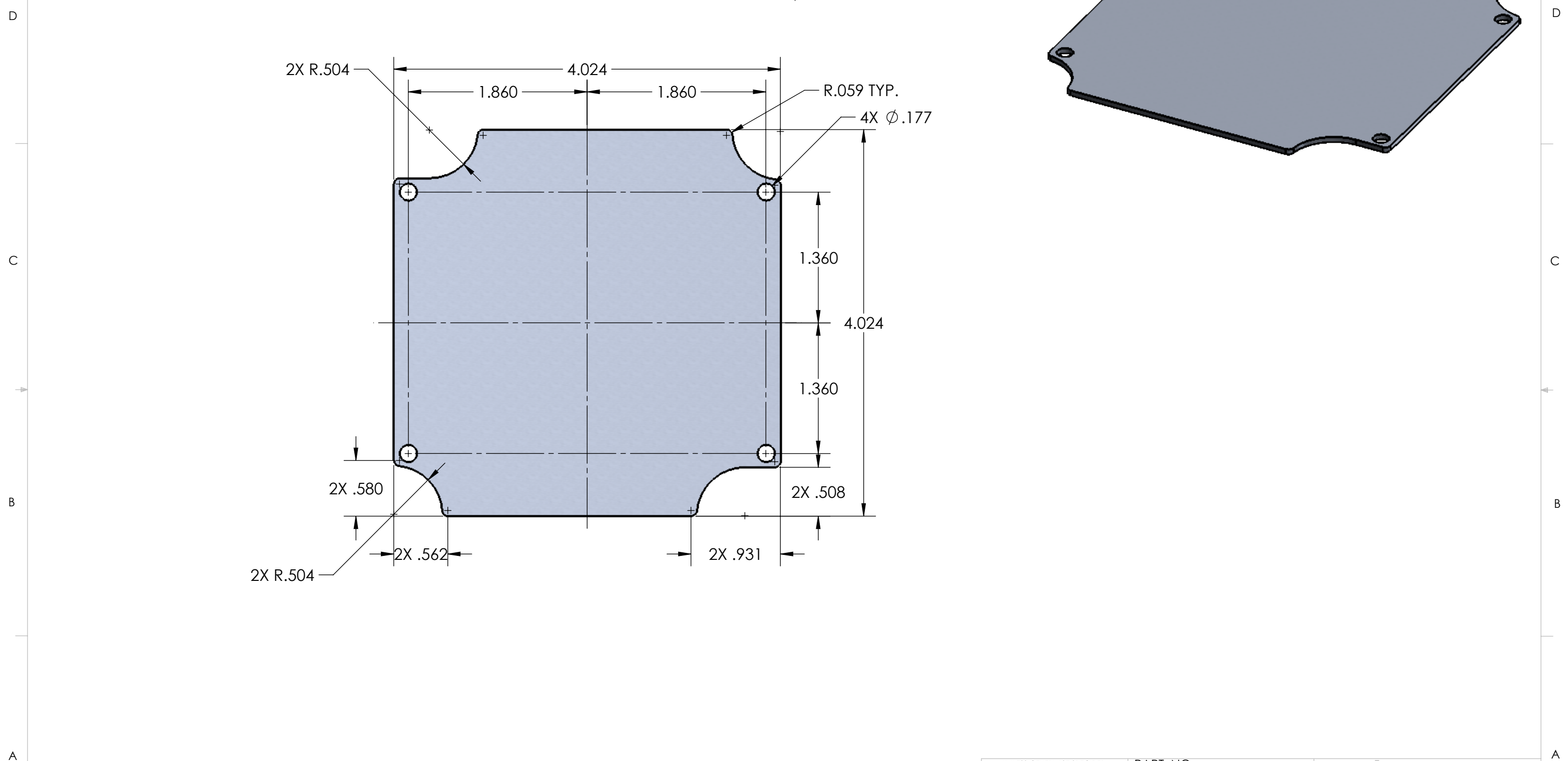

UNLESS OTHERWISE SPECIFIED:
 DIMENSIONS ARE IN: INCHES[mm]
 TOLERANCES: ANGULAR: ±2°
 TWO PLACE DECIMAL: ±.010
 THREE PLACE DECIMAL: ±.005
 PRINTED GRAPHICS: ±.010

PROPRIETARY AND CONFIDENTIAL
 THE INFORMATION CONTAINED IN THIS
 DRAWING IS THE SOLE PROPERTY OF
 POLYCASE. ANY REPRODUCTION IN PART
 OR AS A WHOLE WITHOUT THE WRITTEN
 PERMISSION OF POLYCASE IS PROHIBITED.
 CAD FILE: AN-09-P

PART NO.
 AN-09-P

MATERIAL
 ALUMINUM

FLAME RATING

SIZE
B

ALUMINUM PANEL

REV
 -

SCALE: 1:1

1305 CHESTER IND. PARKWAY AVON, OHIO 44011-1083 U.S.A.
 PH#: 1-800-248-1233, 440-934-0444 FAX#: 440-934-0088

DRAWN	NAME	DATE
CHECKED	D.M.F.	1/4/2017
	C.C.B.	1/6/2017

REV.	DESCRIPTION	ZONE	BY	APPR'D	DATE
	REVISIONS				

8 7 6 5 4 3 2 1