

8 7 6 5 4 3 2 1

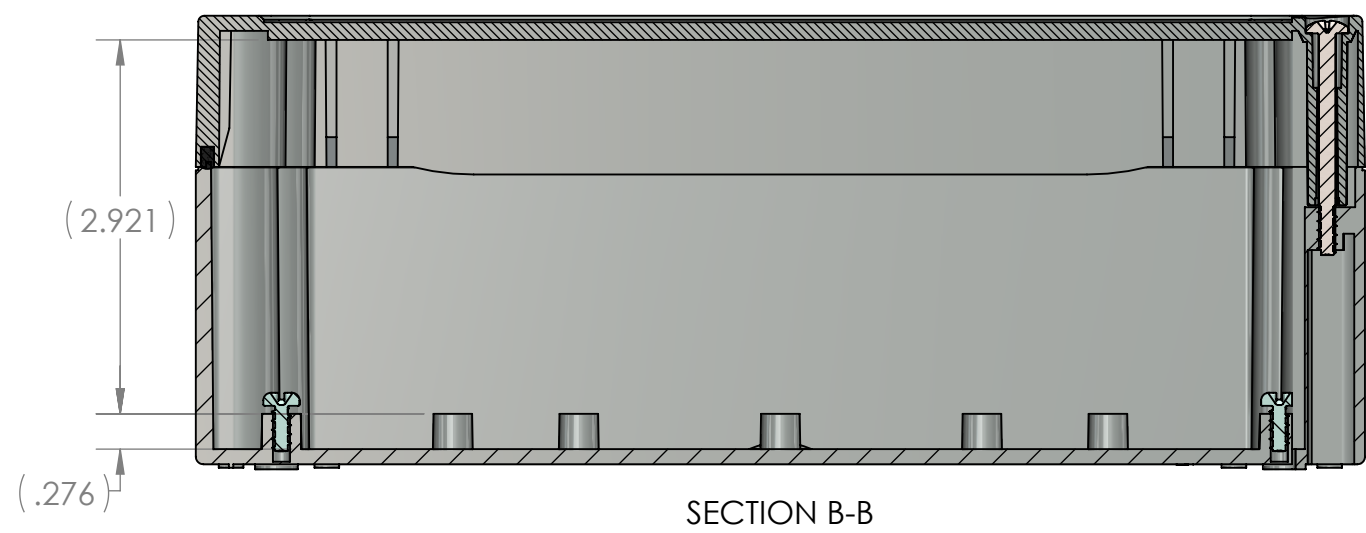

SECTION B-B

BOM Table						
ITEM NO.	PART NUMBER	Rev.	Description	Material	Color	QTY.
1	SG-20B-02	-	BASE	PC	LIGHT GRAY	1
2	SG-16C-02	-.02	COVER	PC	LIGHT GRAY	1
3	SG-KIT-03	-.01	HARDWARE KIT			1
3.1	SCREWS-019	-.01	M3.85x1.8 SPAX X 44mm LG, PAN HEAD, PHILLIPS	304 SST		6
3.2	SCREWS-022	-.01	M3.85x1.8 SPAX X 9mm LG, PAN HEAD, PHILLIPS	QS136-3		4
3.3	SG-97S	-	RETAINER STRAP	PA6	GRAY	2

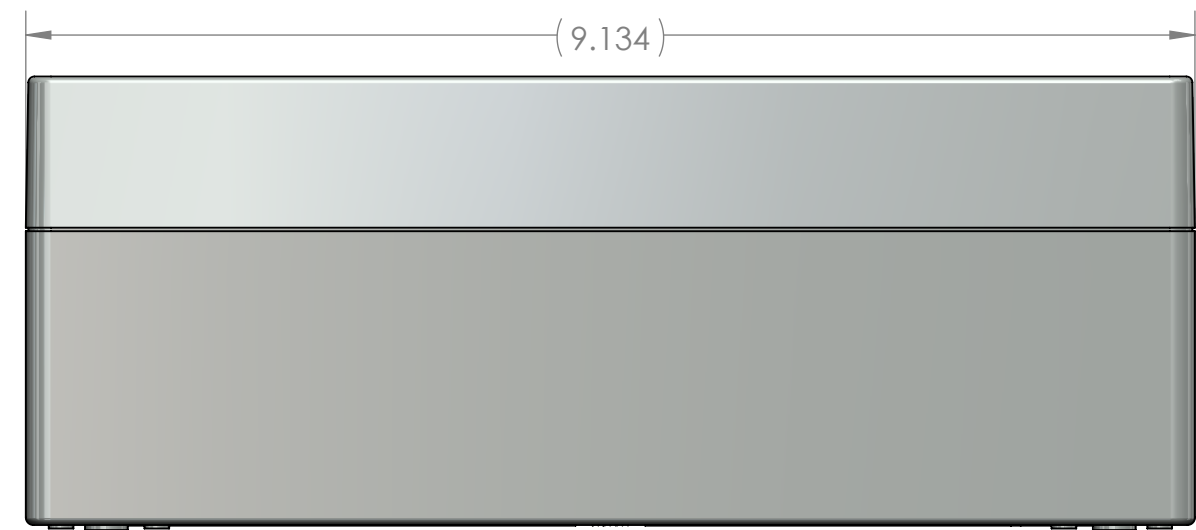
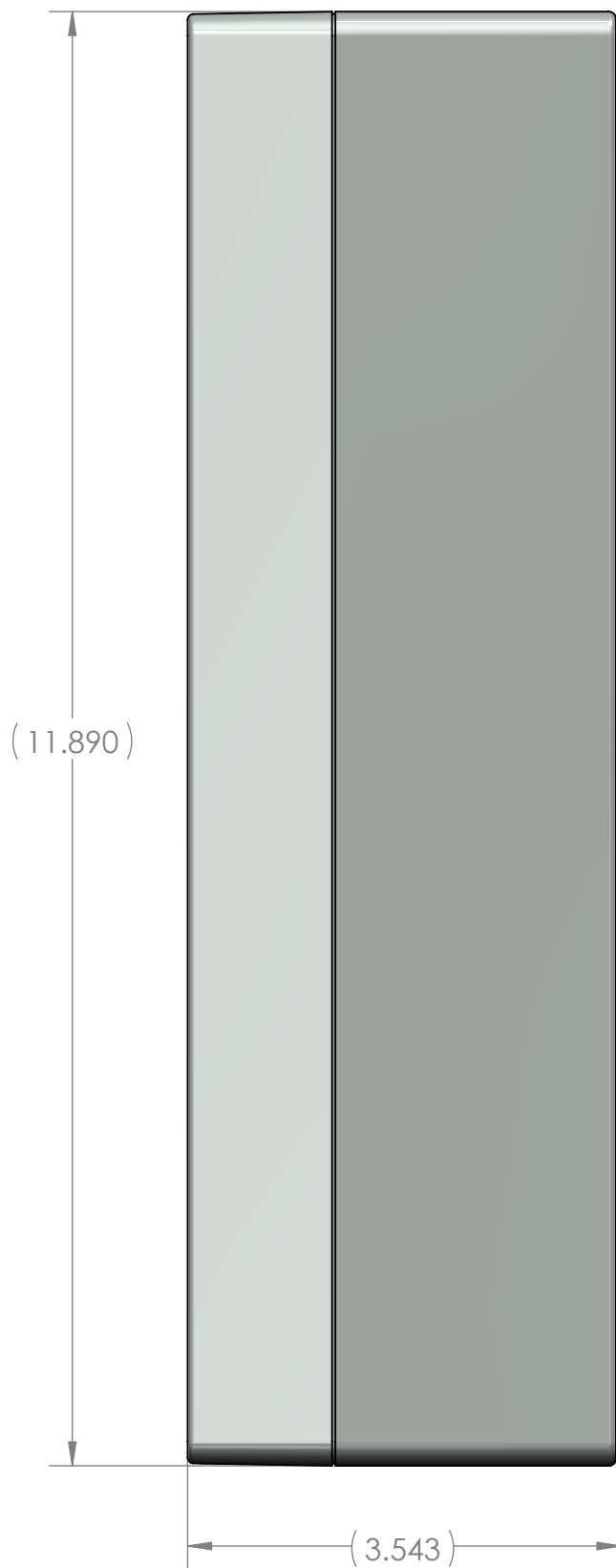
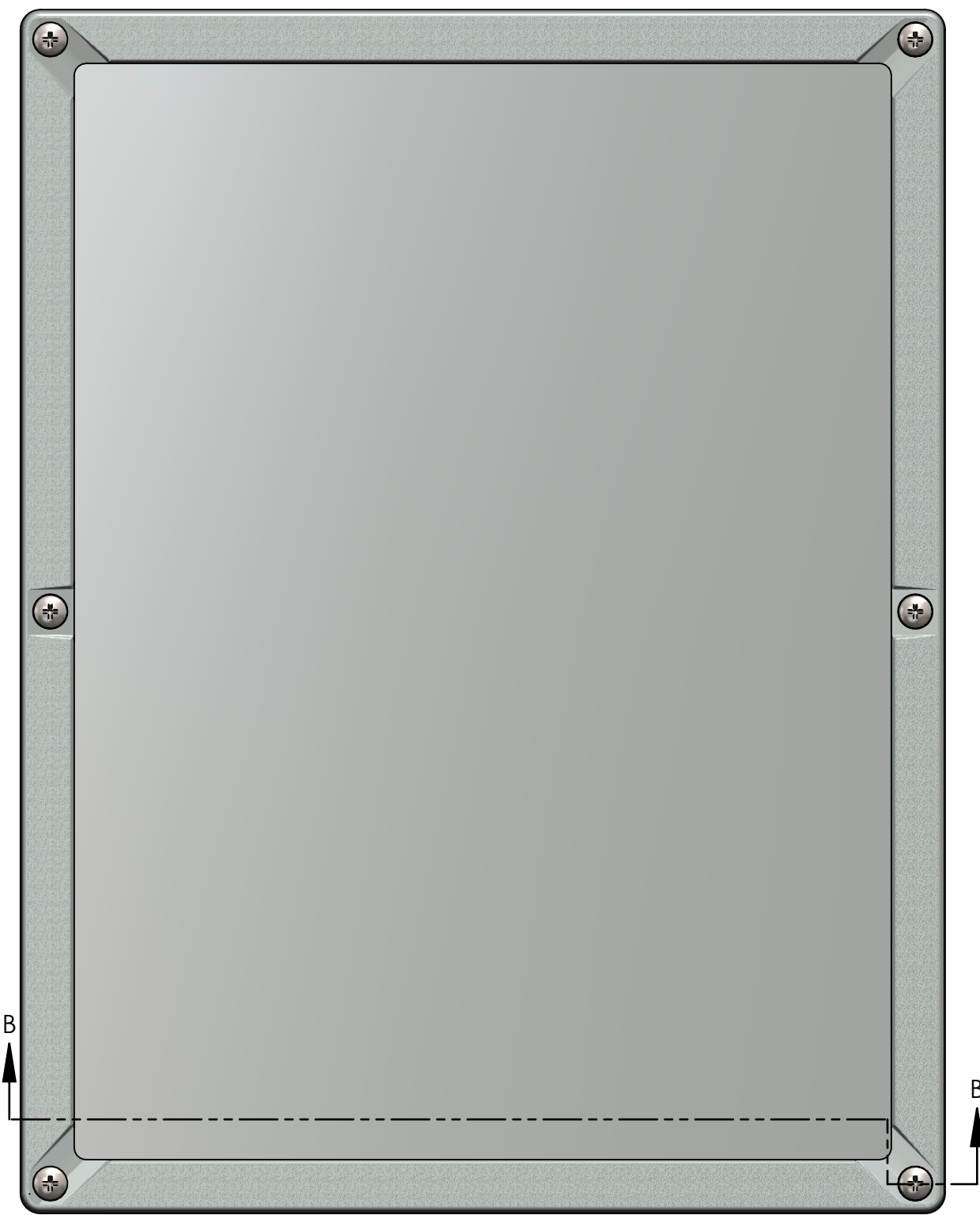
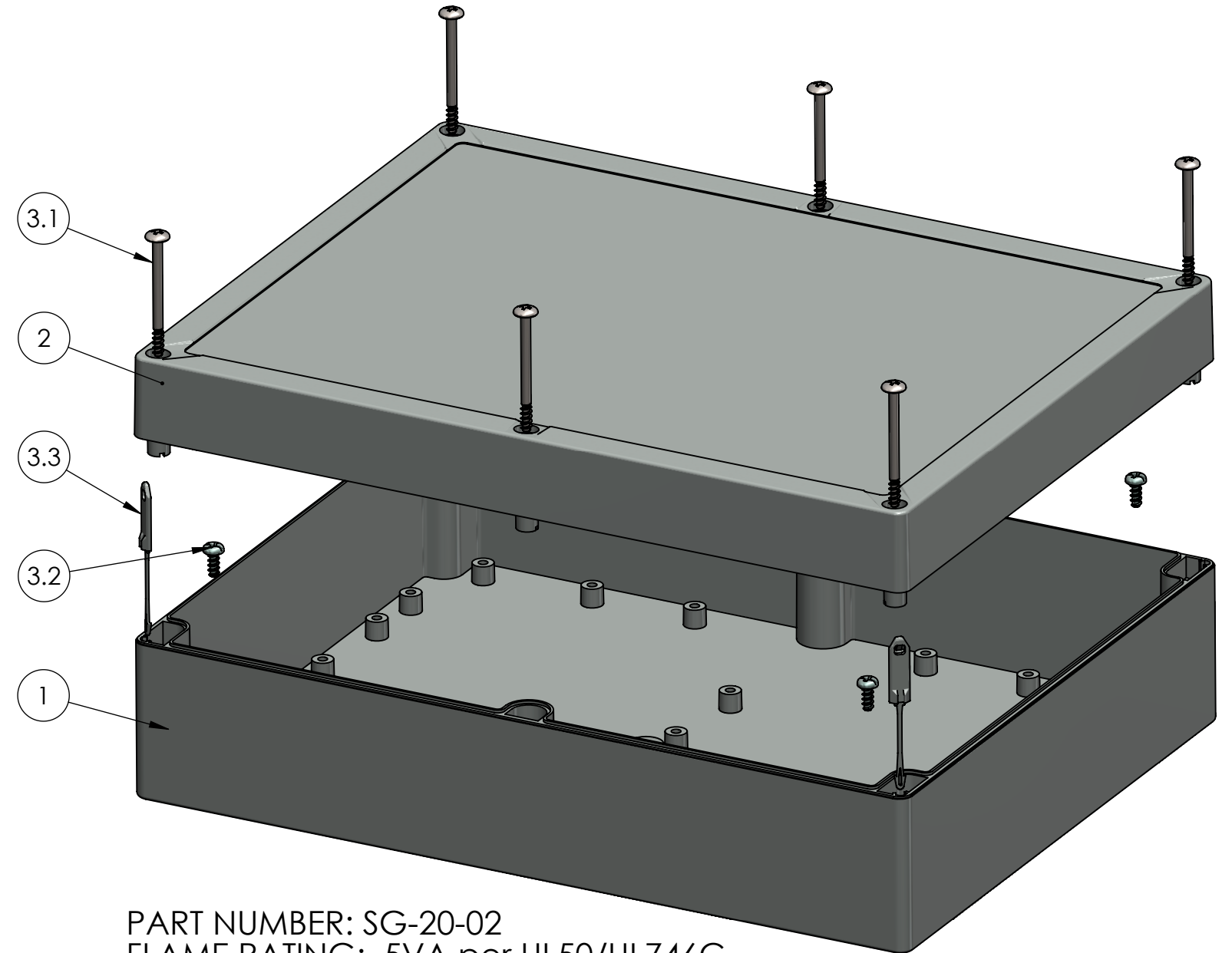

PART NUMBER: SG-20-02  
 FLAME RATING: 5VA per UL50/UL746C

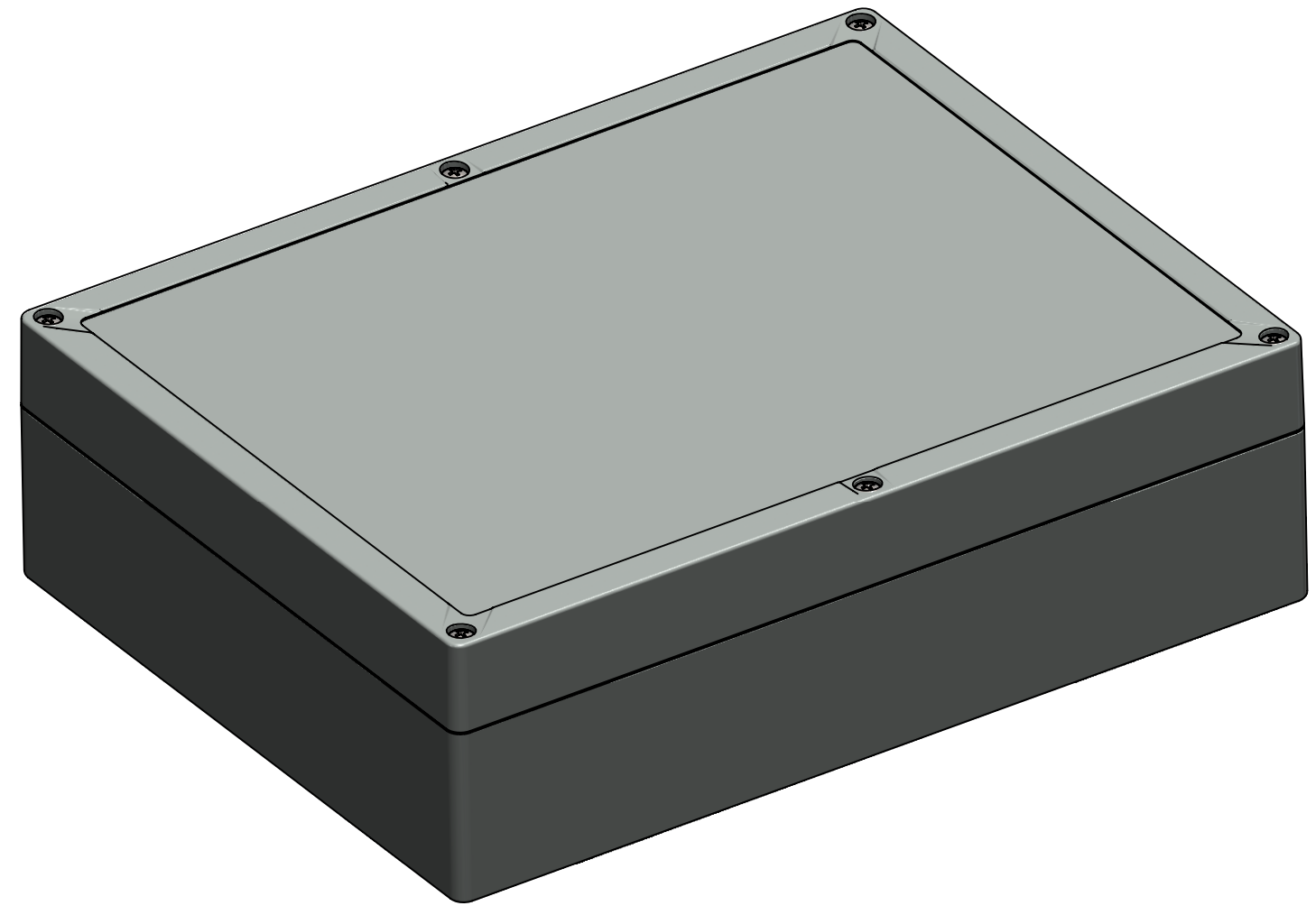

UNLESS OTHERWISE SPECIFIED:  
 DIMENSIONS ARE IN: INCHES[mm]  
 TOLERANCES: ANGULAR: ±2°  
 TWO PLACE DECIMAL: ±.  
 THREE PLACE DECIMAL: ±.  
 PRINTED GRAPHICS: ±.010

PROPRIETARY AND CONFIDENTIAL  
 THE INFORMATION CONTAINED IN THIS  
 DRAWING IS THE SOLE PROPERTY OF  
 POLYCASE. ANY REPRODUCTION IN PART  
 OR AS A WHOLE WITHOUT THE WRITTEN  
 PERMISSION OF POLYCASE IS PROHIBITED.  
 CAD FILE: SG-20

REV.	DESCRIPTION	ZONE	BY	APPR'D	DATE
	REVISIONS				

PART NO. SEE BOM	MATERIAL	FLAME RATING	SIZE C
			SCALE: 1:1.5

1305 CHESTER RD. PARKWAY AVON, OHIO 44011-1083 U.S.A.  
 PH: 1-800-248-1233 440-934-0444 FAX: 440-934-0088

polycase

REV -

DRAWN: [Name] DATE: 10/9/2017  
 CHECKED: [Name] DATE: 9/8/2015

SHEET 1 OF 2

8 7 6 5 4 3 2 1

BOM Table						
ITEM NO.	PART NUMBER	Rev.	Description	Material	Color	QTY.
1	SG-20B-02	-	BASE	PC	LIGHT GRAY	1
2	SG-16C-03	-.02	COVER	PC	CLEAR	1
3	SG-KIT-03	-.01	HARDWARE KIT			1
3.1	SCREWS-019	-.01	M3.85x1.8 SPAX X 44mm LG, PAN HEAD, PHILLIPS	304 SST		6
3.2	SCREWS-022	-.01	M3.85x1.8 SPAX X 9mm LG, PAN HEAD, PHILLIPS	QS136-3		4
3.3	SG-97S	-	RETAINER STRAP	PA6	GRAY	2

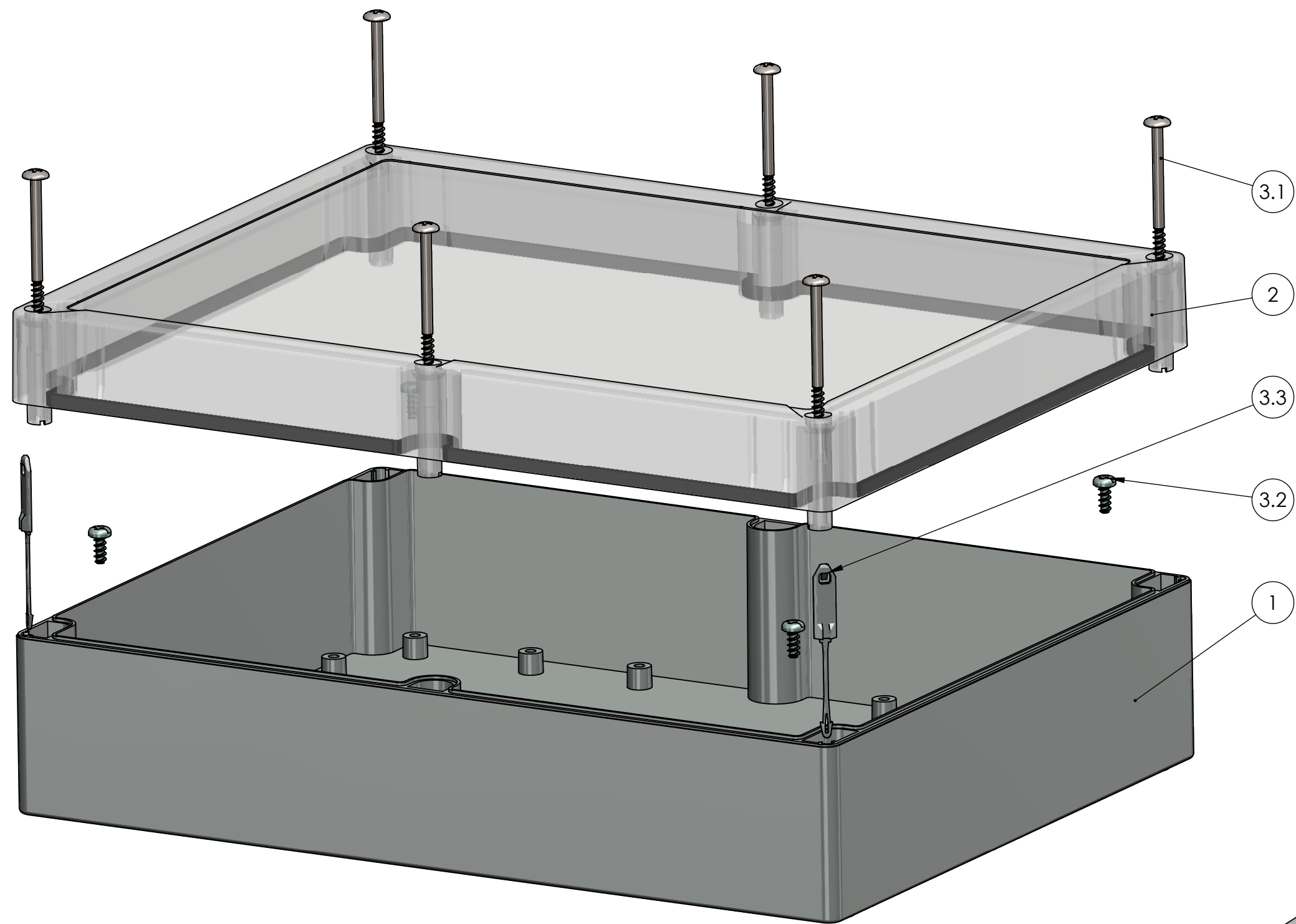

PART NUMBER: SG-20-03  
 FLAME RATING: 5VA per UL50/UL746C

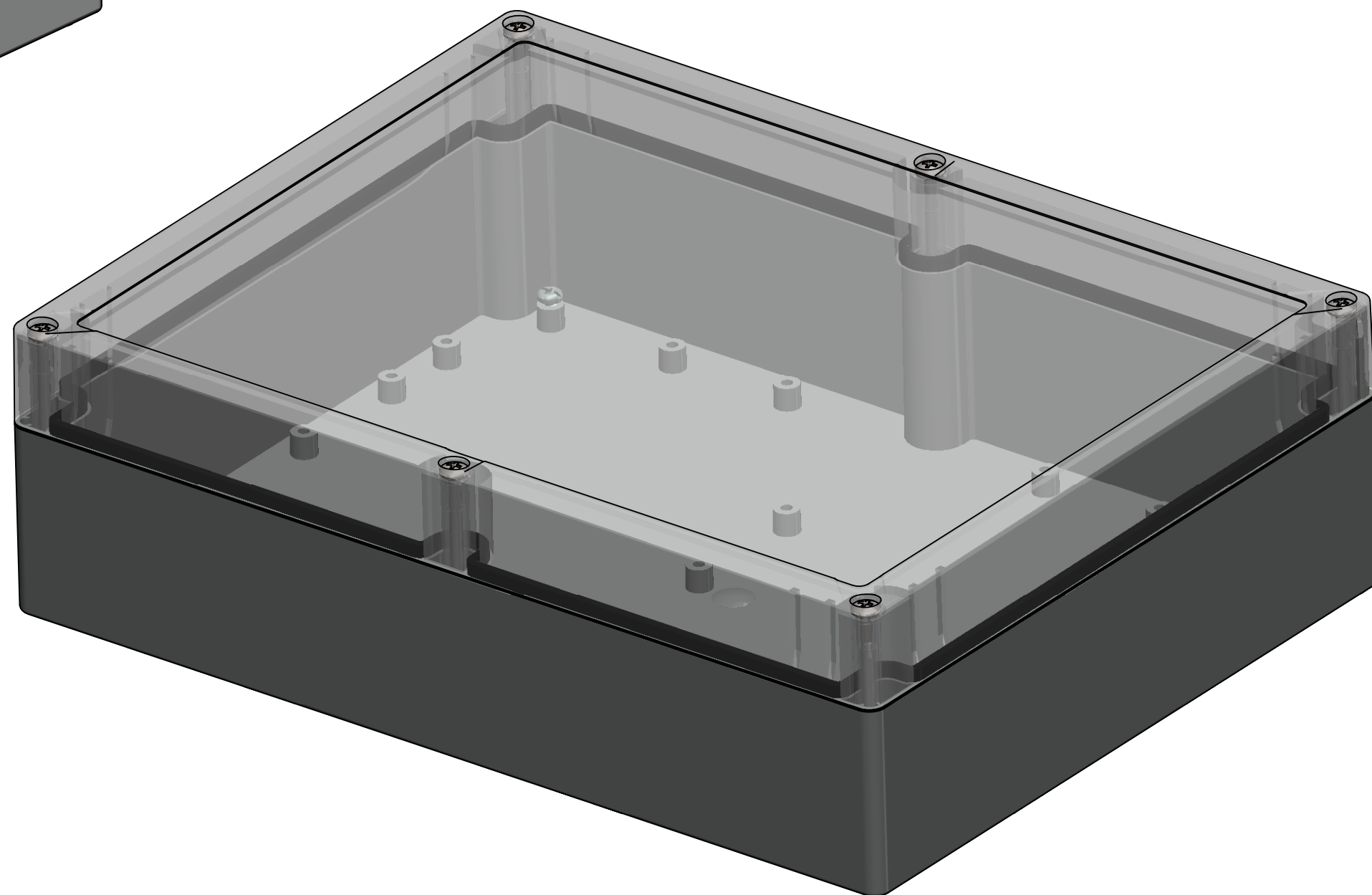

UNLESS OTHERWISE SPECIFIED: DIMENSIONS ARE IN: INCHES[mm] TOLERANCES: ANGULAR: ±2° TWO PLACE DECIMAL: ± THREE PLACE DECIMAL: ± PRINTED GRAPHICS: ±0.10		PART NO. SEE BOM		 <small>1305 CHESTER RD. PARKWAY AVON, OHIO 44011-1083 U.S.A.        PH: 1-800-248-1233 440-934-0444 FAX: 440-934-0088</small>	
PROPRIETARY AND CONFIDENTIAL THE INFORMATION CONTAINED IN THIS DRAWING IS THE SOLE PROPERTY OF POLYCASE. ANY REPRODUCTION IN PART OR AS A WHOLE WITHOUT THE WRITTEN PERMISSION OF POLYCASE IS PROHIBITED. CAD FILE: SG-20		MATERIAL			
FLAME RATING		SIZE		REV	
DRAWN		NAME		DATE	
CHECKED		D.M.F.		10/9/2017	
				9/8/2015	
SCALE: 1:1.5				SHEET 2 OF 2	

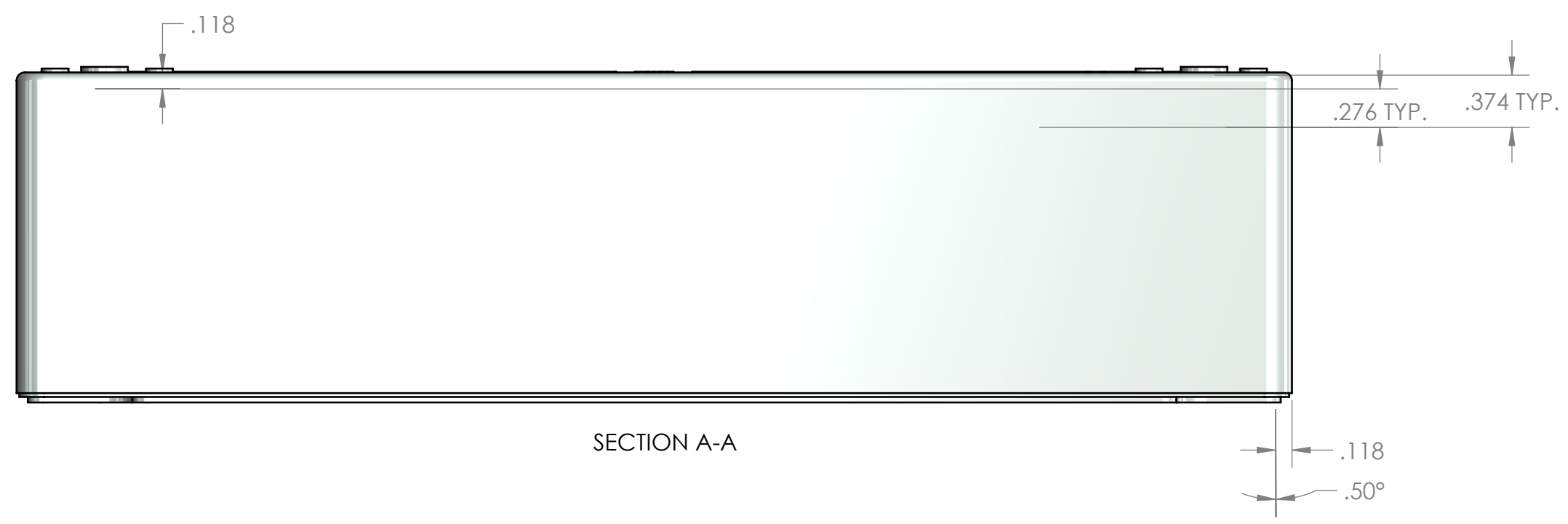

SECTION A-A

PART NUMBER: SG-20B-02  
COLOR: LIGHT GRAY

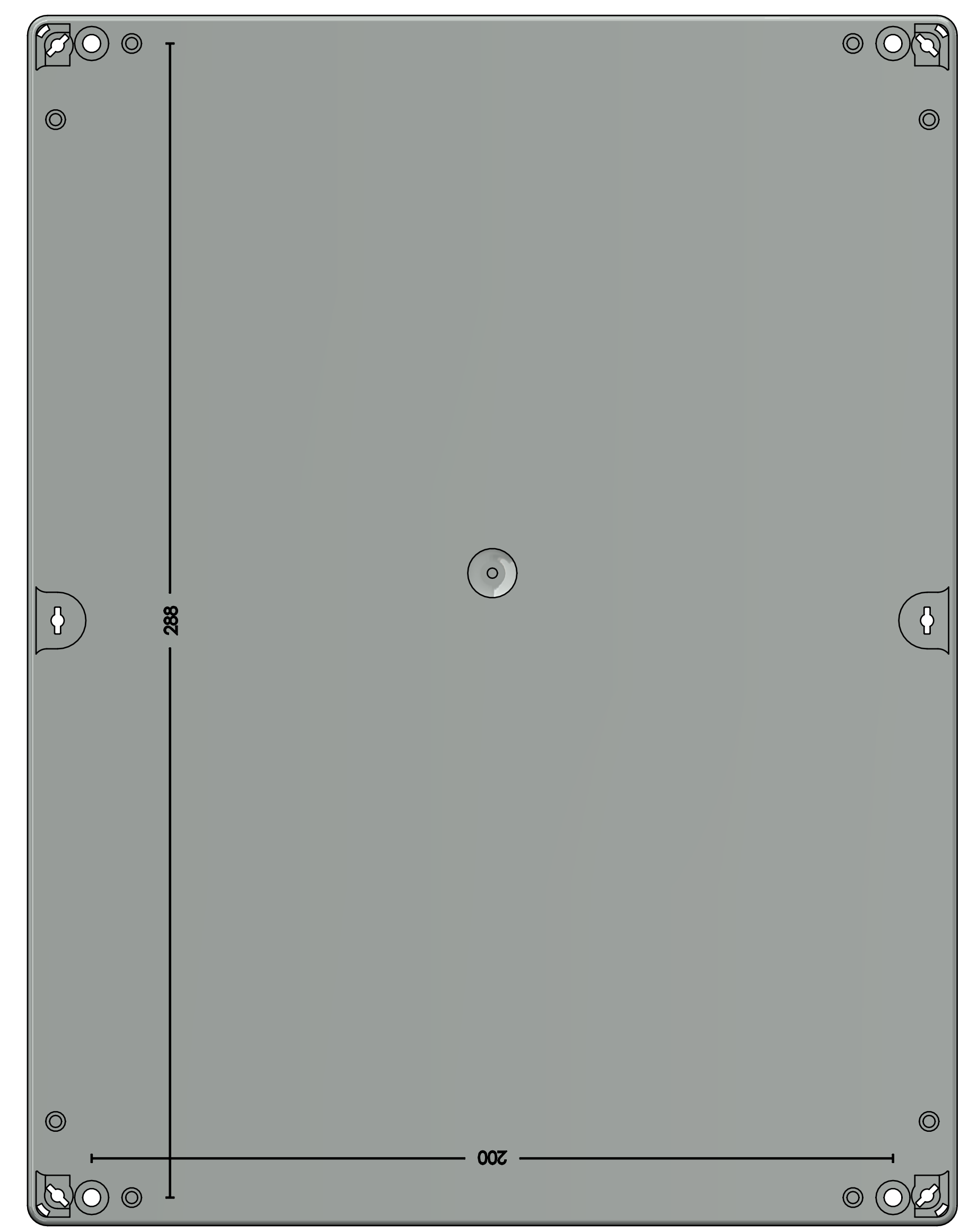
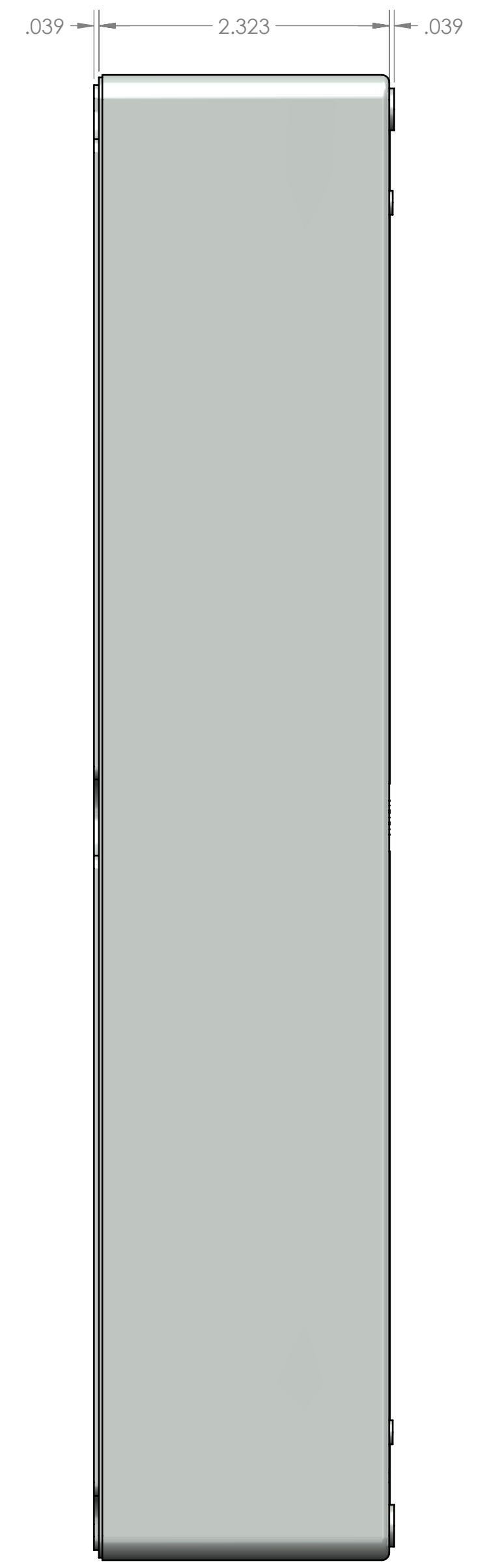
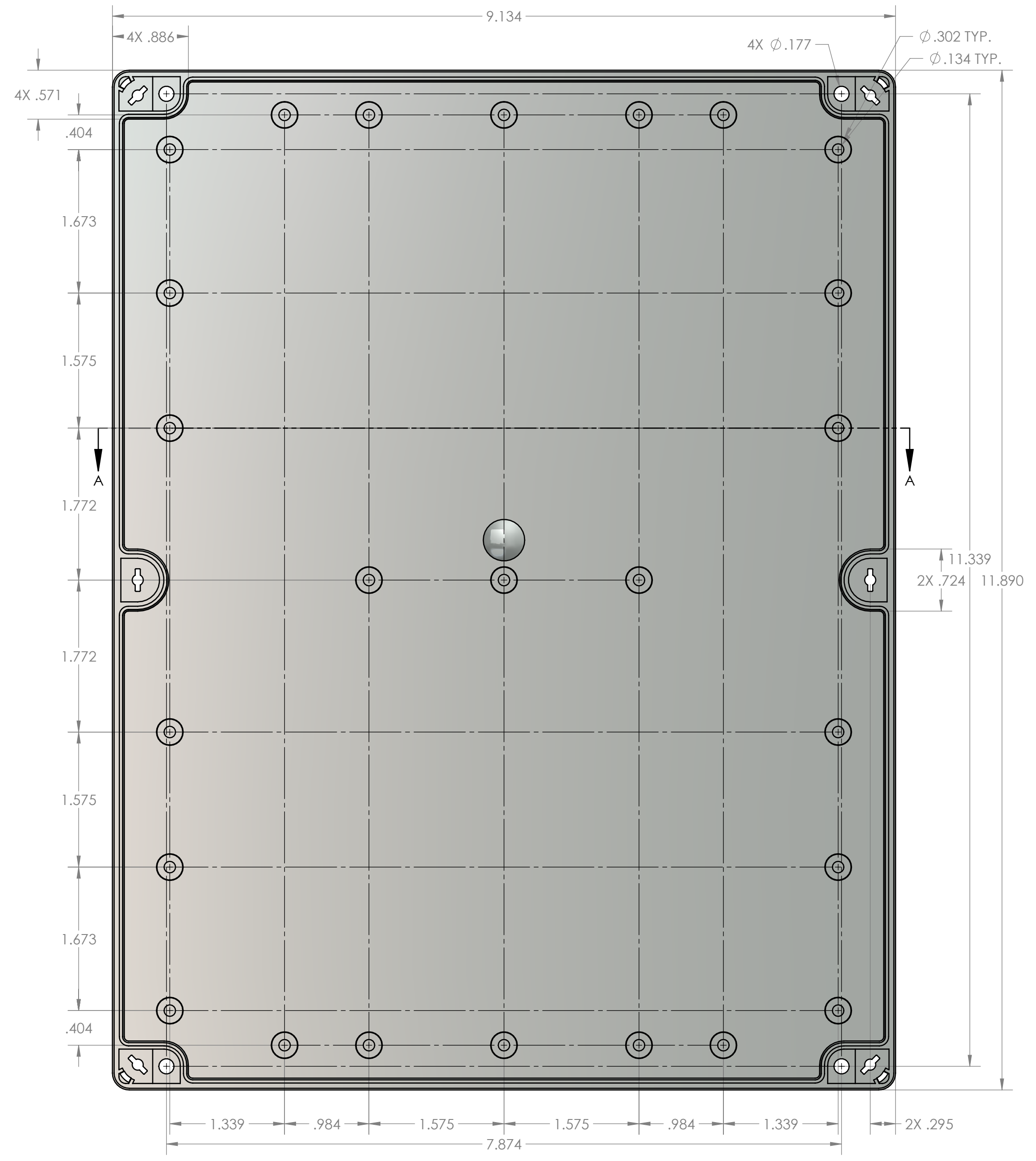
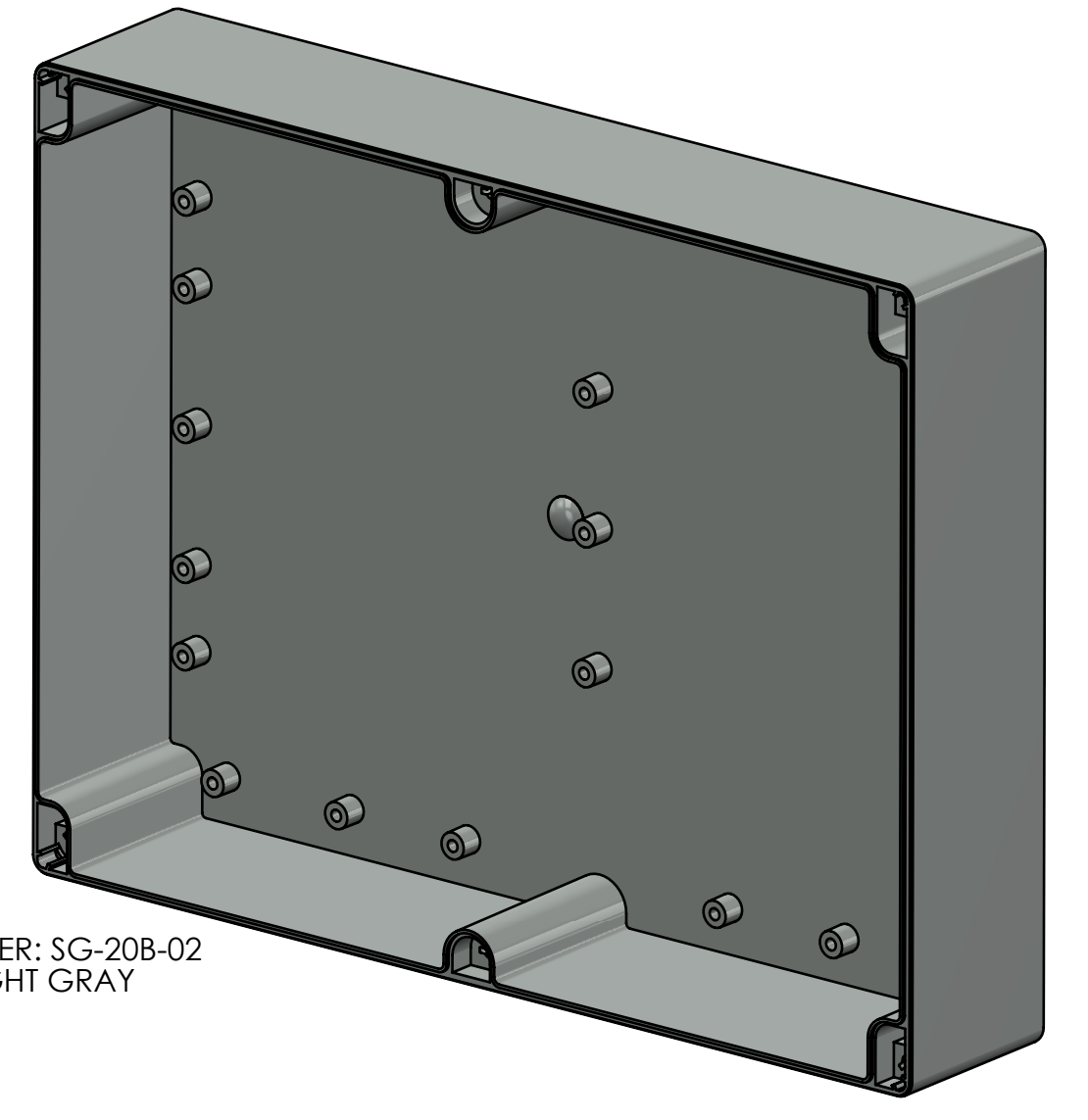

UNLESS OTHERWISE SPECIFIED: DIMENSIONS ARE IN INCHES (TYP) TOLERANCES: ANGULAR: ±2° TWO PLACE DECIMAL: ±.02 THREE PLACE DECIMAL: ±.005 PRINTED GRAPHICS: 1:500				PART NO. SG-20B-02		polycase 1785 CHESTER HWY. HANWAY PA, PA 17041-1003 U.S.A. TEL: 800-288-1222, 480-534-9844 FAX: 480-534-9888
PROPERTY AND CONFIDENTIAL THE INFORMATION CONTAINED IN THIS DRAWING IS THE SOLE PROPERTY OF POLYCASE. ANY REPRODUCTION IN PART OR AS A WHOLE WITHOUT THE WRITTEN PERMISSION OF POLYCASE IS PROHIBITED. CAD FILE: SG-20B				MATERIAL PC		
FLAME RATING				SIZE D		BASE REV -
DRAWN D.M.F. 10/9/2017				DATE 9/2/2015		
SCALE: 1:1				SHEET 1 OF 1		

REV.	DESCRIPTION	ZONE	BY	APPR'D	DATE

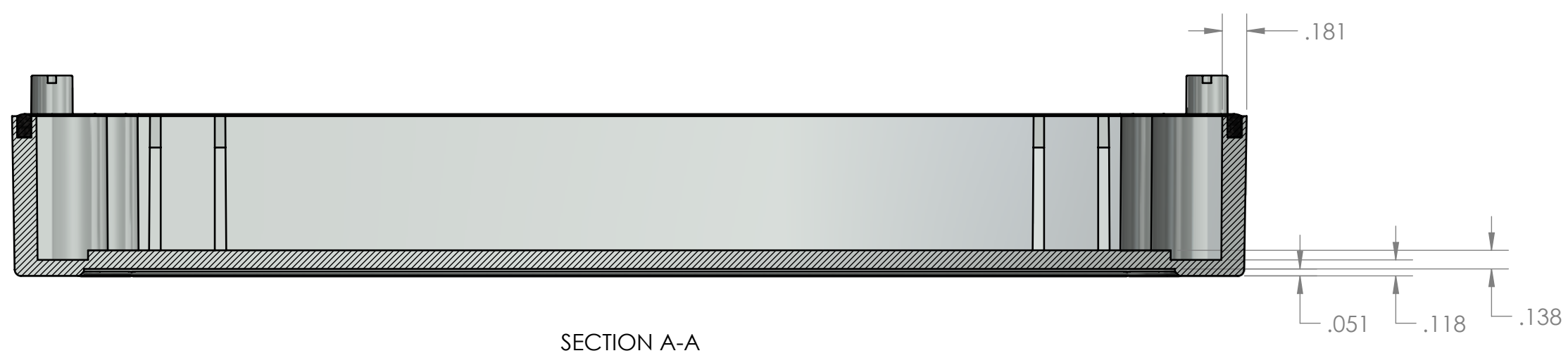

SECTION A-A

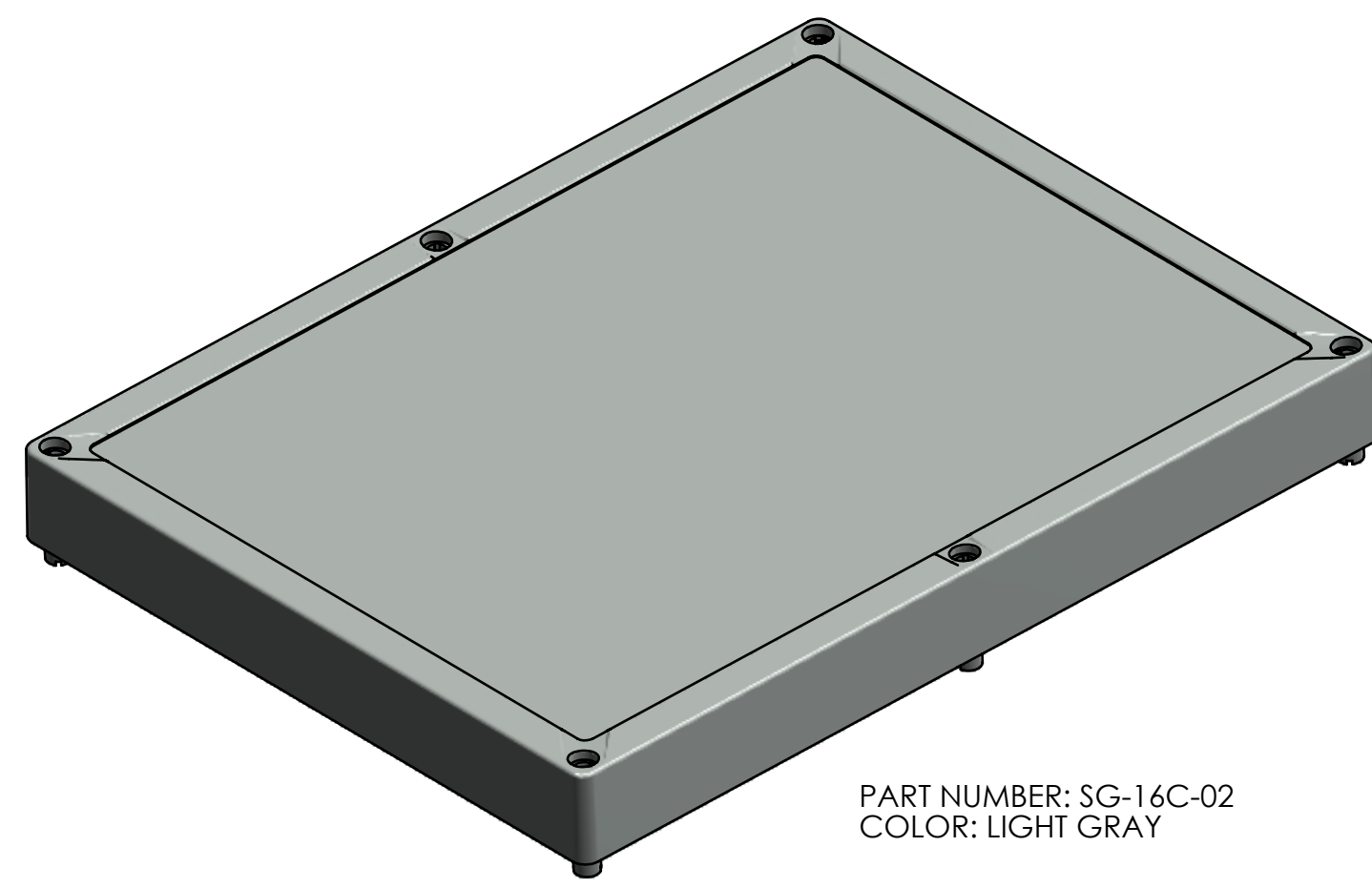

PART NUMBER: SG-16C-02  
COLOR: LIGHT GRAY

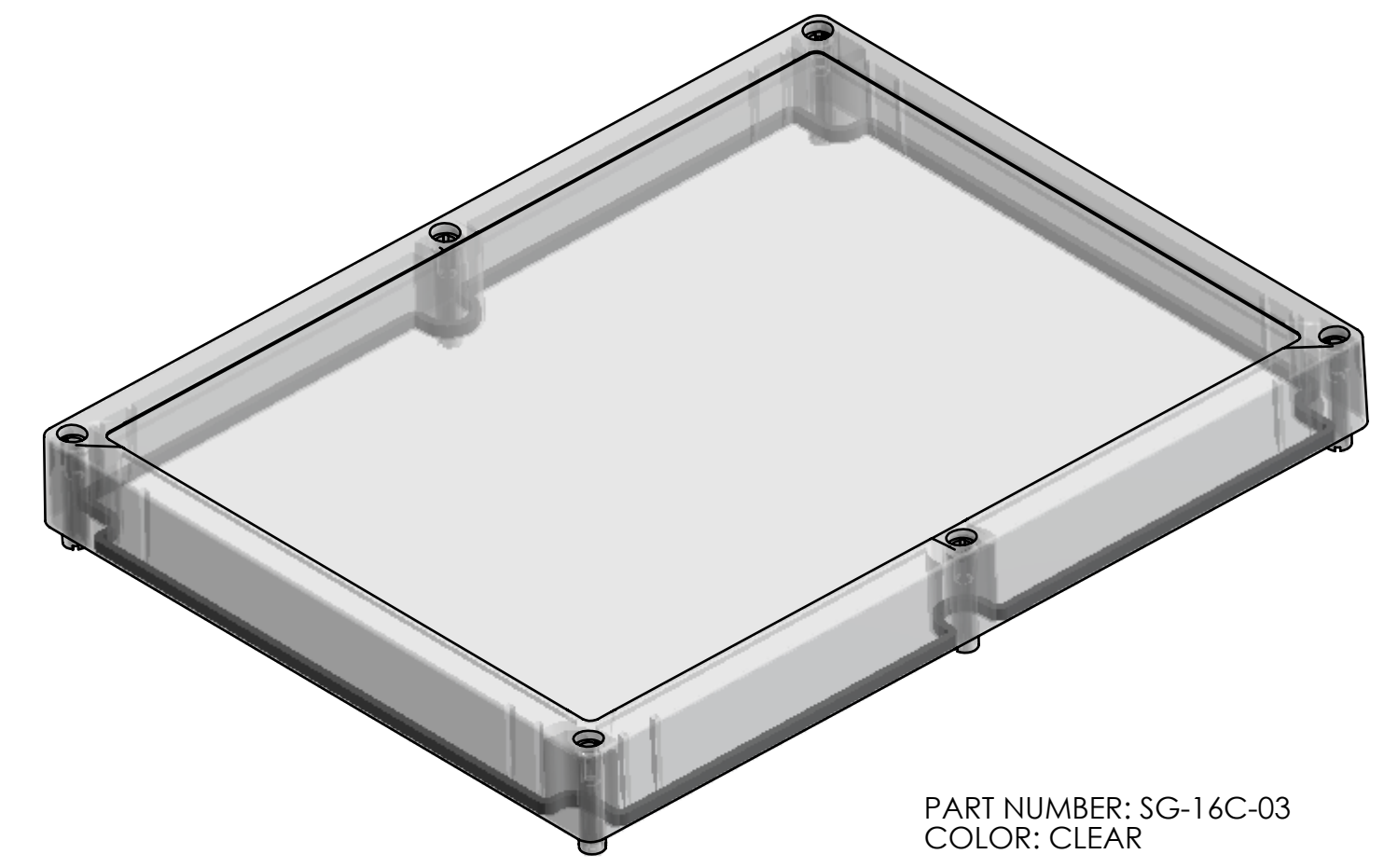

PART NUMBER: SG-16C-03  
COLOR: CLEAR

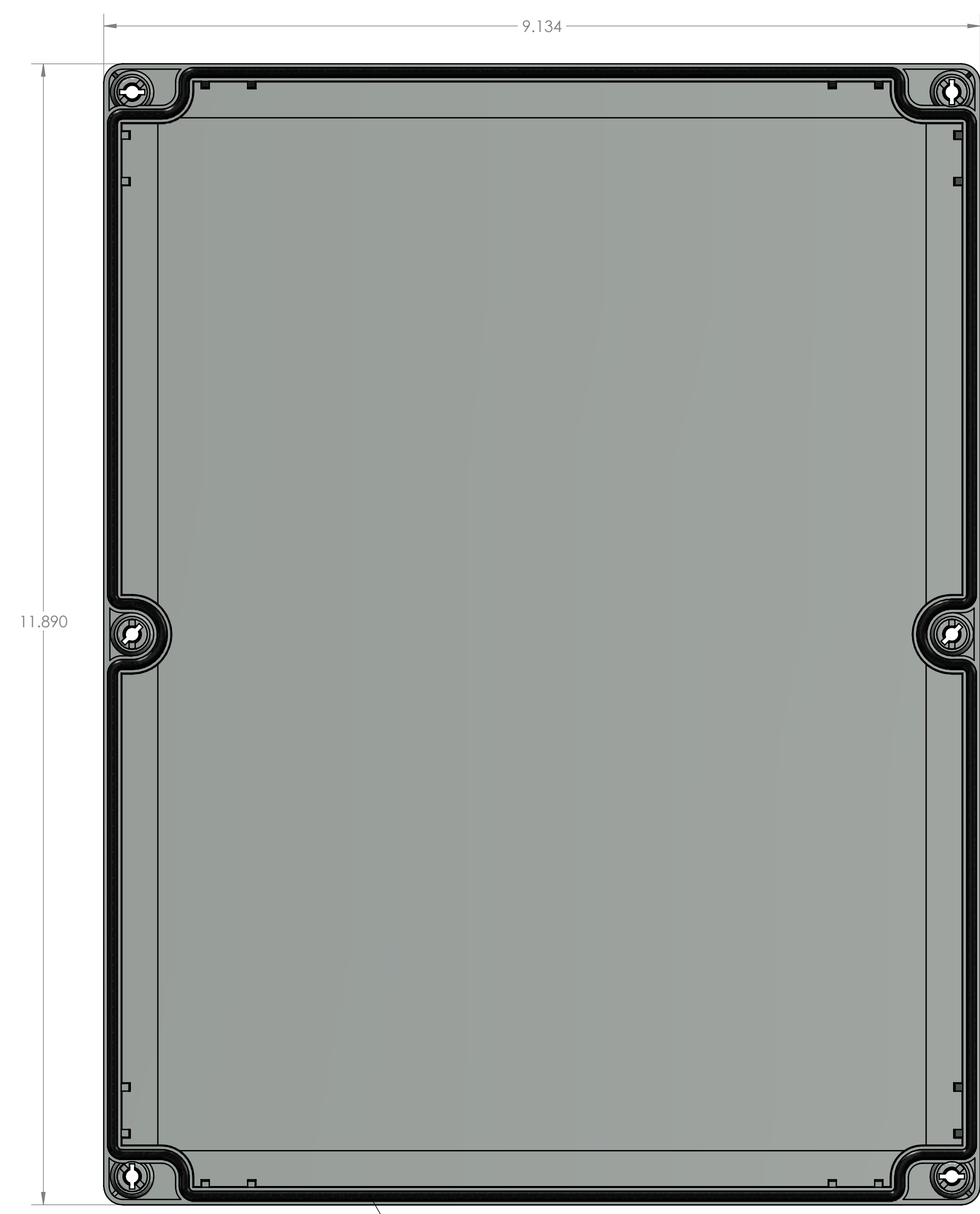
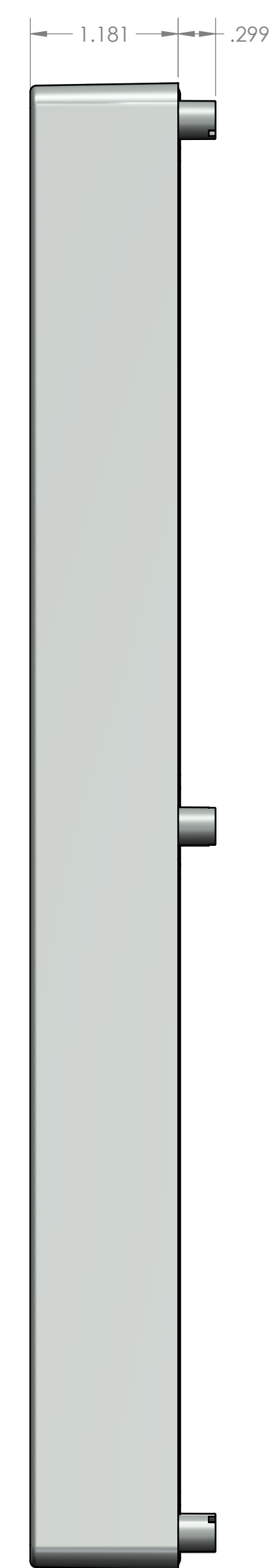
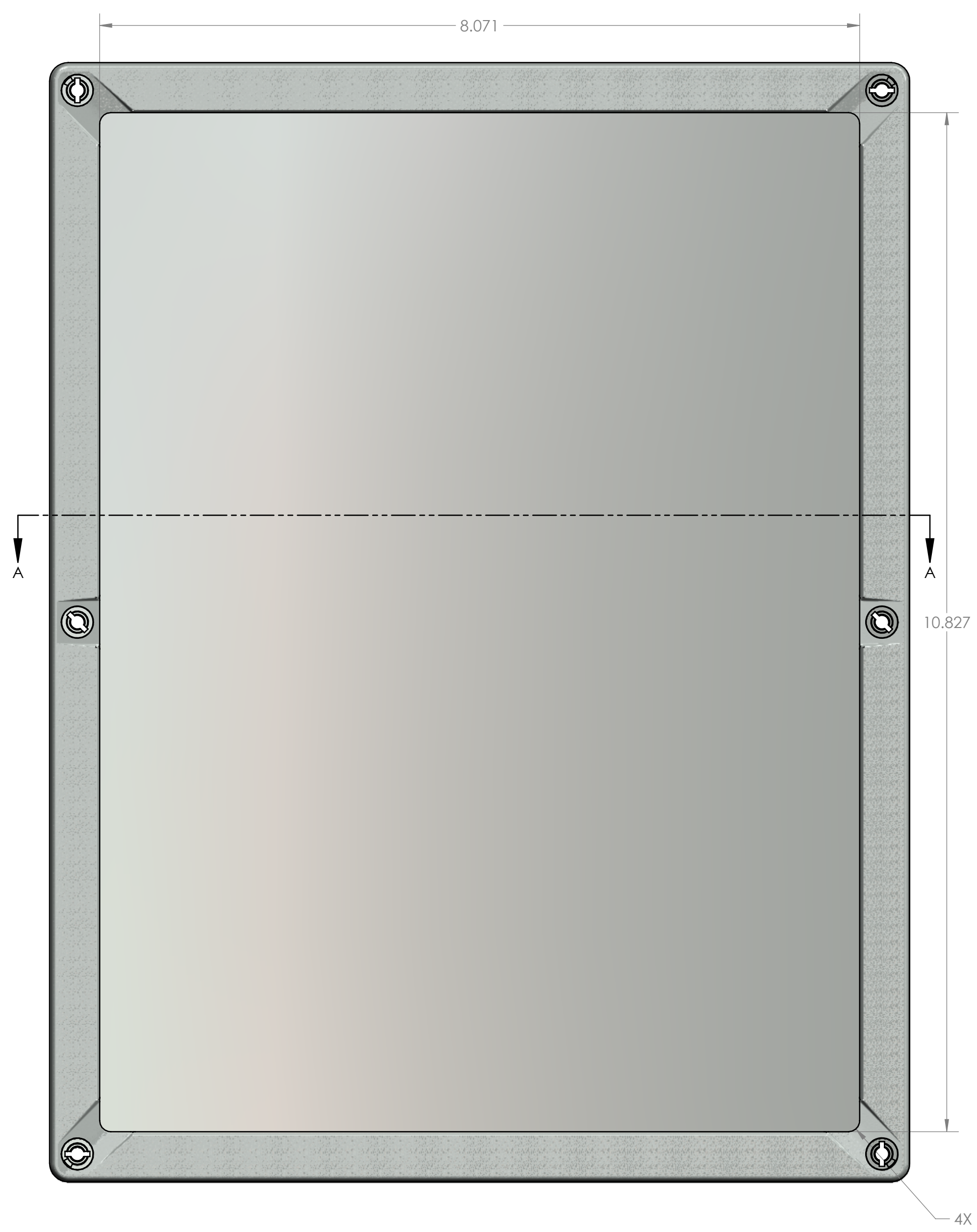

POLYURETHANE GASKET

UNLESS OTHERWISE SPECIFIED: DIMENSIONS ARE IN INCHES/TYPICAL TOLERANCES: ANGULAR: 22° TWO PLACE DECIMAL: ±. THREE PLACE DECIMAL: ±. PRINTED GRAPHICS: 1:510		PART NO. SG-16C		polycase 1705 CHESTER WILKINSON PARK, OHIO 44111-1003 U.S.A. PH: 1-800-285-1222 FAX: 1-419-944-1434
PROPERTY AND CONFIDENTIAL INFORMATION CONTAINED IN THIS DRAWING IS THE SOLE PROPERTY OF POLYCASE. ANY REPRODUCTION IN PART OR AS A WHOLE WITHOUT THE WRITTEN PERMISSION OF POLYCASE IS PROHIBITED. CAD FILE: SG-16C		MATERIAL PC		
FLAME RATING		SIZE D		REV -01
DRAWN: D.M.F. 8/18/2015		SCALE: 1:1		SHEET 1 OF 1
CHECKED: B.M.B. 9/8/2015				