

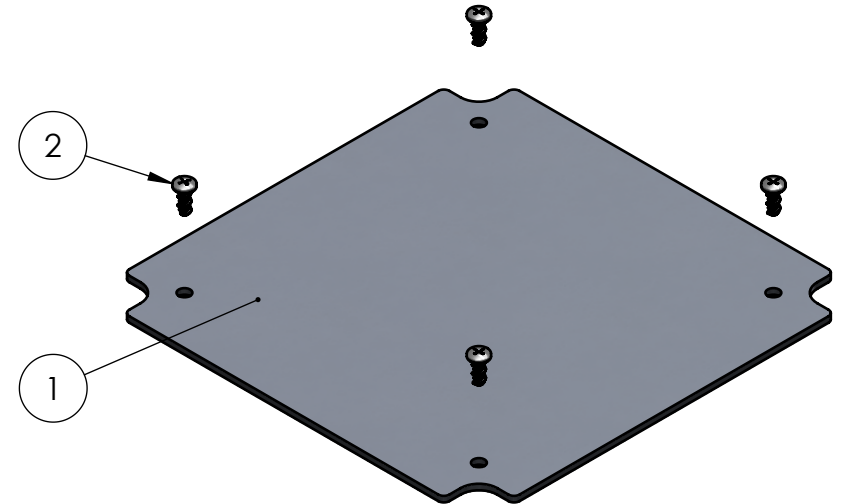

BOM Table

ITEM NO.	PART NUMBER	Rev.	Description	Material	QTY.
1	DC-44-P	-	MOUNTING PANEL	AL 5052-H32	1
2	SCREWS-MBR	-.01	#4-24 HI-LO X .25 THREAD FORMING, PHILLIPS, PAN HEAD, SCREW	AISI 1019-1022	4

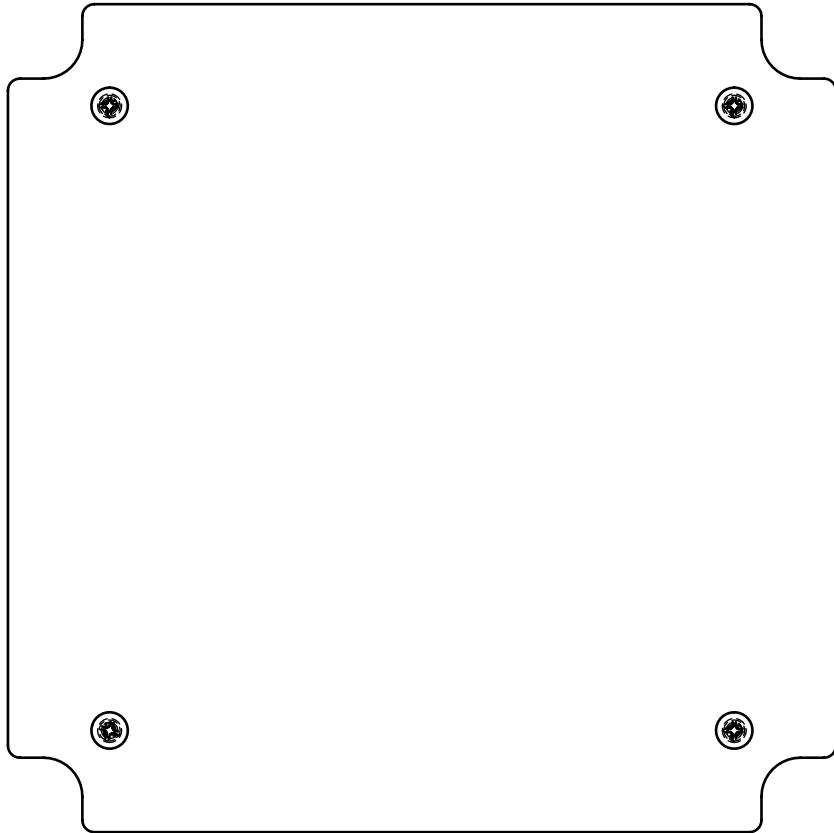
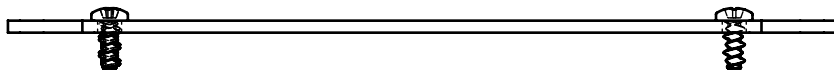

SCALE 1 : 1.5



UNLESS OTHERWISE SPECIFIED: DIMENSIONS ARE IN: INCHES[mm] TOLERANCES: ANGULAR: ±2° TWO PLACE DECIMAL: ±.010 THREE PLACE DECIMAL: ±.005 PRINTED GRAPHICS: ±.010				PART NO. DC-44K		 <small>1305 CHESTER IND. PARKWAY AVON, OHIO 44011-1083 U.S.A. PH#: 1-800-248-1233, 440-934-0444 FAX#: 440-934-0088</small>					
PROPRIETARY AND CONFIDENTIAL THE INFORMATION CONTAINED IN THIS DRAWING IS THE SOLE PROPERTY OF POLYCASE. ANY REPRODUCTION IN PART OR AS A WHOLE WITHOUT THE WRITTEN PERMISSION OF POLYCASE IS PROHIBITED. CAD FILE: DC-44K				MATERIAL				FLAME RATING	SIZE <b>A</b>	MOUNTING PANEL KIT	REV -
REV.	DESCRIPTION	ZONE	BY	APPR'D	DATE	DRAWN	NAME	DATE	SCALE: 1:1		SHEET 1 OF 1

5

4



3

2

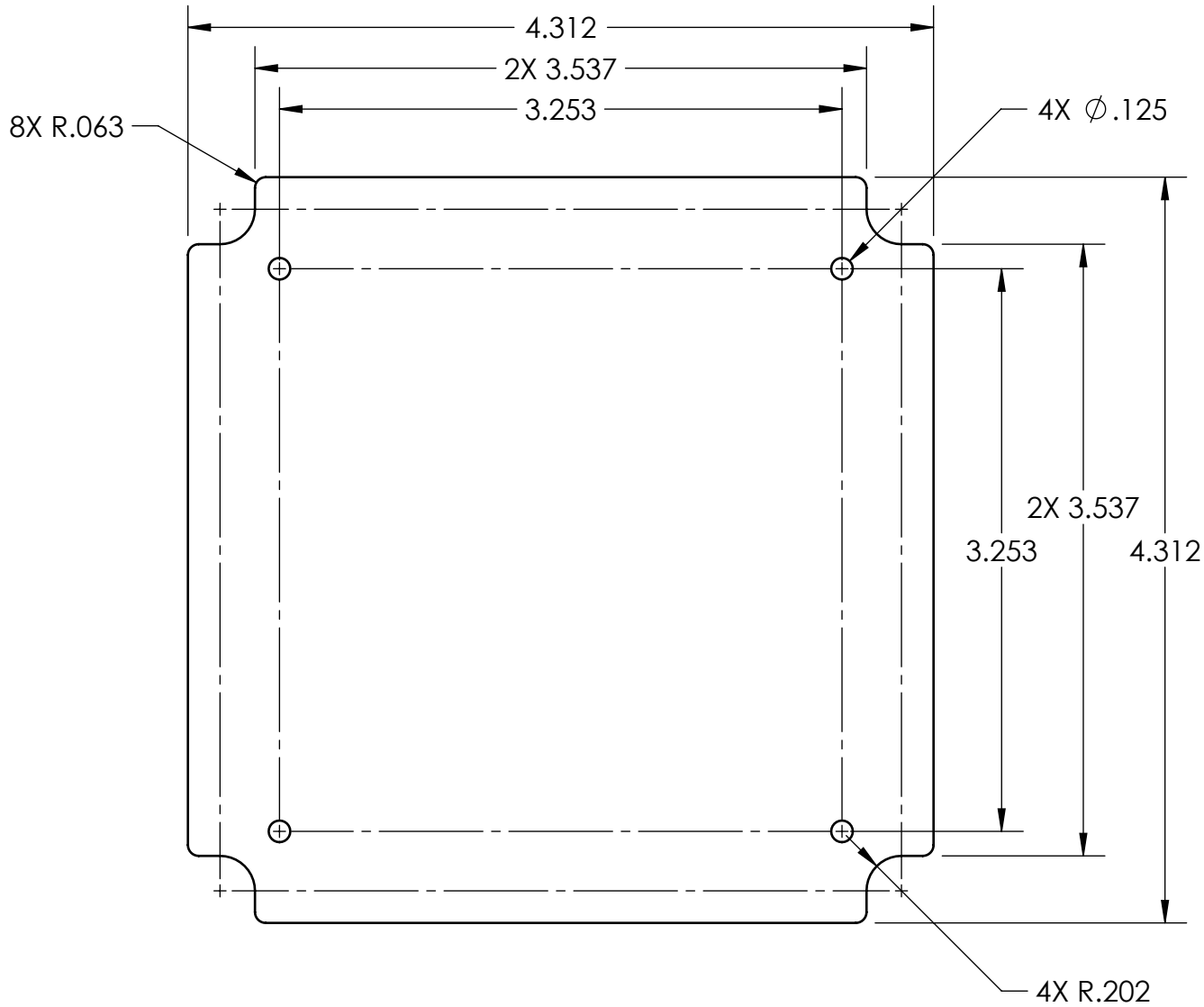
1



NOTES:  
 1. BREAK ALL EDGES .005 MAX

UNLESS OTHERWISE SPECIFIED: DIMENSIONS ARE IN: INCHES [mm] TOLERANCES: ANGULAR: ±2° TWO PLACE DECIMAL: ±.010 THREE PLACE DECIMAL: ±.005 PRINTED GRAPHICS: ±.010	PART NO. DC-44-P		 <small>1305 CHESTER IND. PARKWAY AVON, OHIO 44011-1083 U.S.A.          PH#: 1-800-248-1233, 440-934-0444 FAX#: 440-934-0088</small>																			
	MATERIAL AL 5052-H32																					
PROPRIETARY AND CONFIDENTIAL THE INFORMATION CONTAINED IN THIS DRAWING IS THE SOLE PROPERTY OF POLYCASE. ANY REPRODUCTION IN PART OR AS A WHOLE WITHOUT THE WRITTEN PERMISSION OF POLYCASE IS PROHIBITED. CAD FILE: DC-44-P	FLAME RATING		SIZE <b>A</b>	MOUNTING PANEL	REV -																	
	<table border="1"> <thead> <tr> <th>REV.</th> <th>DESCRIPTION</th> <th>ZONE</th> <th>BY</th> <th>APPR'D</th> <th>DATE</th> </tr> </thead> <tbody> <tr> <td> </td> <td> </td> <td> </td> <td> </td> <td> </td> <td> </td> </tr> </tbody> </table>	REV.	DESCRIPTION	ZONE	BY	APPR'D	DATE							<table border="1"> <thead> <tr> <th>NAME</th> <th>DATE</th> </tr> </thead> <tbody> <tr> <td>D.M.F.</td> <td>5/1/2013</td> </tr> <tr> <td>B.M.B.</td> <td>5/7/2013</td> </tr> </tbody> </table>	NAME	DATE	D.M.F.	5/1/2013	B.M.B.	5/7/2013	SCALE: 1:1	
REV.	DESCRIPTION	ZONE	BY	APPR'D	DATE																	
NAME	DATE																					
D.M.F.	5/1/2013																					
B.M.B.	5/7/2013																					

5

4

3

2

1

D  
C  
B  
A