

BOM Table						
ITEM NO.	PART NUMBER	Rev.	Description	Material	Color	QTY.
1	SG-18B-02	-	BASE	PC	LIGHT GRAY	1
2	SG-11C-02	-.01	COVER	PC	LIGHT GRAY	1
3	SG-KIT-01	-.01	HARDWARE KIT			1
3.1	SCREWS-018	-.01	M3.85x1.8 SPAX X 29mm LG, PAN HEAD, PHILLIPS	304 SST		4
3.2	SCREWS-022	-.01	M3.85x1.8 SPAX X 9mm LG, PAN HEAD, PHILLIPS	QS136-3		4
3.3	SG-98S	-.01	RETAINER STRAP	PA6	GRAY	2

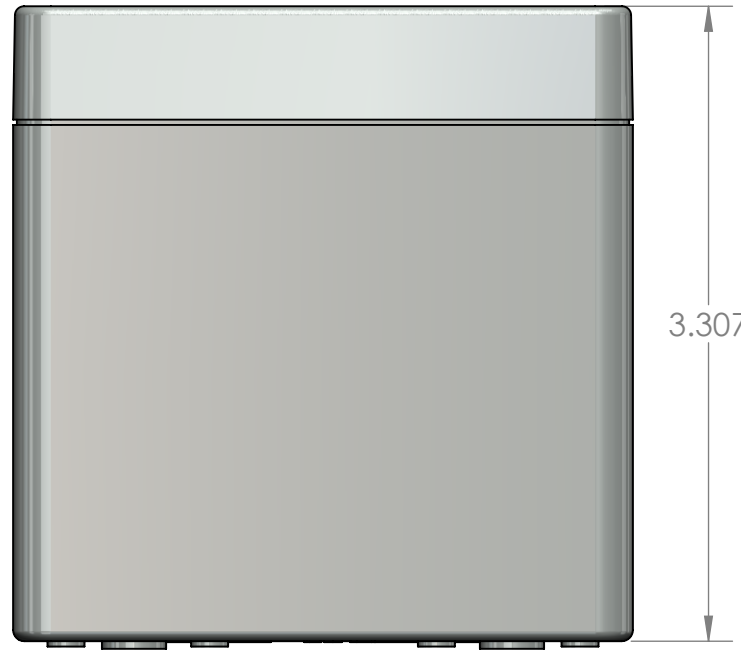
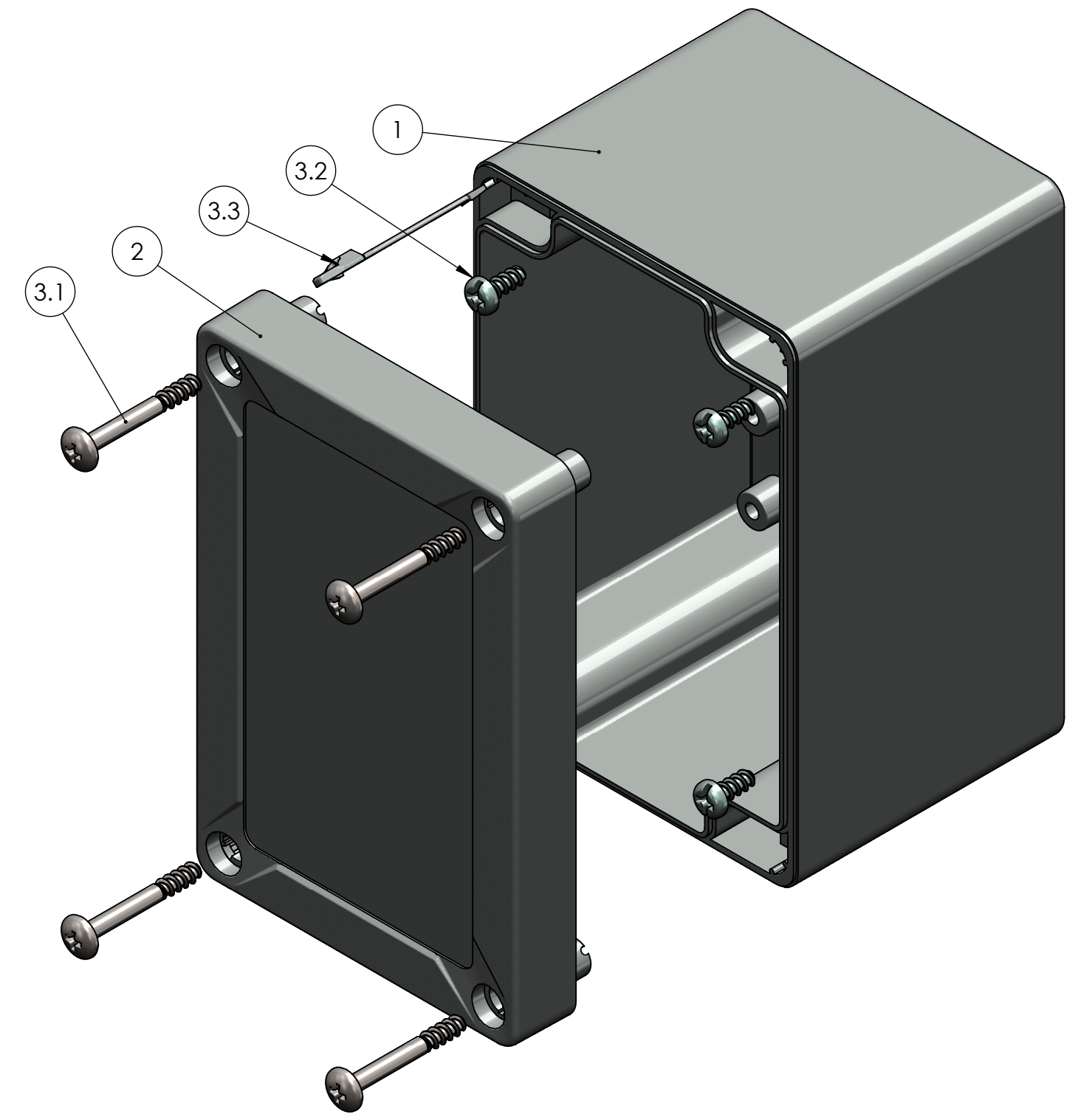
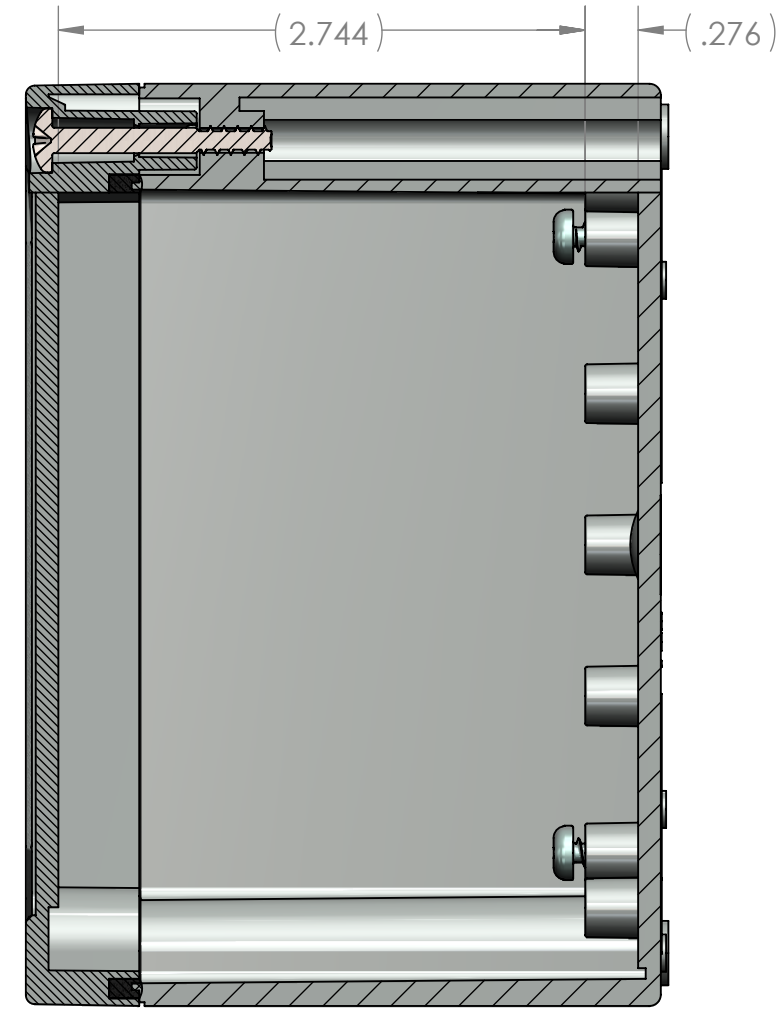
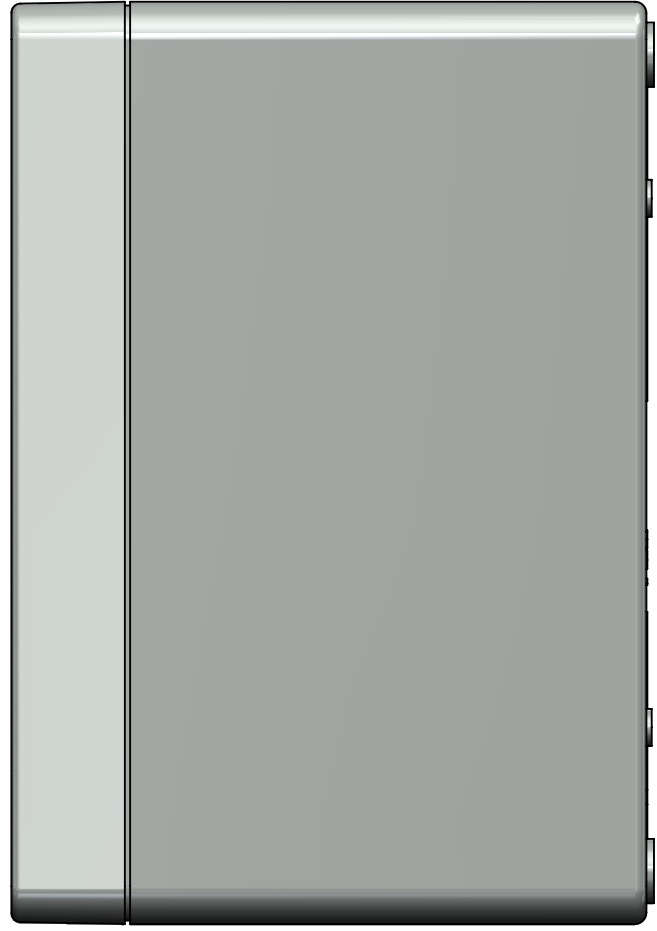
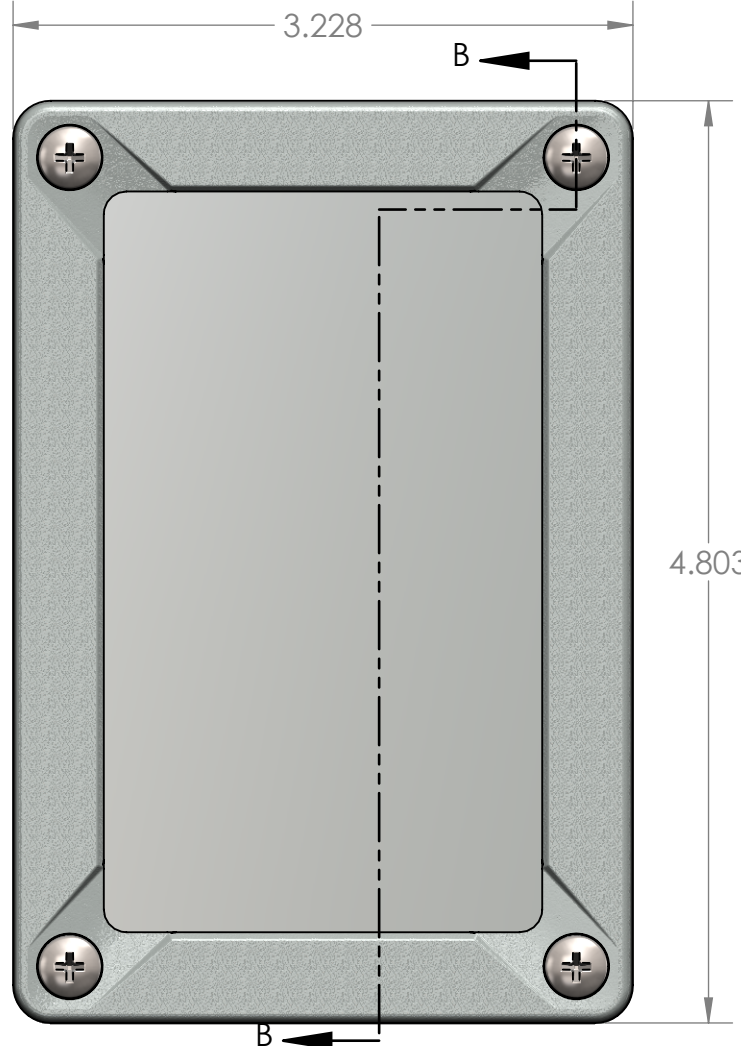

PART NUMBER: SG-18-02
 FLAME RATING: 5VA per UL50/UL746C

UNLESS OTHERWISE SPECIFIED:
 DIMENSIONS ARE IN: INCHES[mm]
 TOLERANCES: ANGULAR: ±2°
 TWO PLACE DECIMAL: ±.
 THREE PLACE DECIMAL: ±.
 PRINTED GRAPHICS: ±.010

PROPRIETARY AND CONFIDENTIAL
 THE INFORMATION CONTAINED IN THIS
 DRAWING IS THE SOLE PROPERTY OF
 POLYCASE. ANY REPRODUCTION IN PART
 OR AS A WHOLE WITHOUT THE WRITTEN
 PERMISSION OF POLYCASE IS PROHIBITED.
 CAD FILE: SG-18

PART NO.
 SEE BOM

MATERIAL

FLAME RATING

SIZE
 C

SCALE: 1:1

1305 CHESTER RD. PARKWAY AVON, OHIO 44011-1083 U.S.A.
 PH: 1-800-248-1233, 440-934-0444 FAX: 440-934-0088

REV

SHEET 1 OF 2

REV.	DESCRIPTION	ZONE	BY	APPR'D	DATE
REVISIONS					

REV.	NAME	DATE
DRAWN	D.M.F.	10/9/2017
CHECKED	-	9/8/2015

8 7 6 5 4 3 2 1

BOM Table						
ITEM NO.	PART NUMBER	Rev.	Description	Material	Color	QTY.
1	SG-18B-02	-	BASE	PC	LIGHT GRAY	1
2	SG-11C-03	-.01	COVER	PC	CLEAR	1
3	SG-KIT-01	-.01	HARDWARE KIT			1
3.1	SCREWS-018	-.01	M3.85x1.8 SPAX X 29mm LG, PAN HEAD, PHILLIPS	304 SST		4
3.2	SCREWS-022	-.01	M3.85x1.8 SPAX X 9mm LG, PAN HEAD, PHILLIPS	QSt36-3		4
3.3	SG-98S	-.01	RETAINER STRAP	PA6	GRAY	2

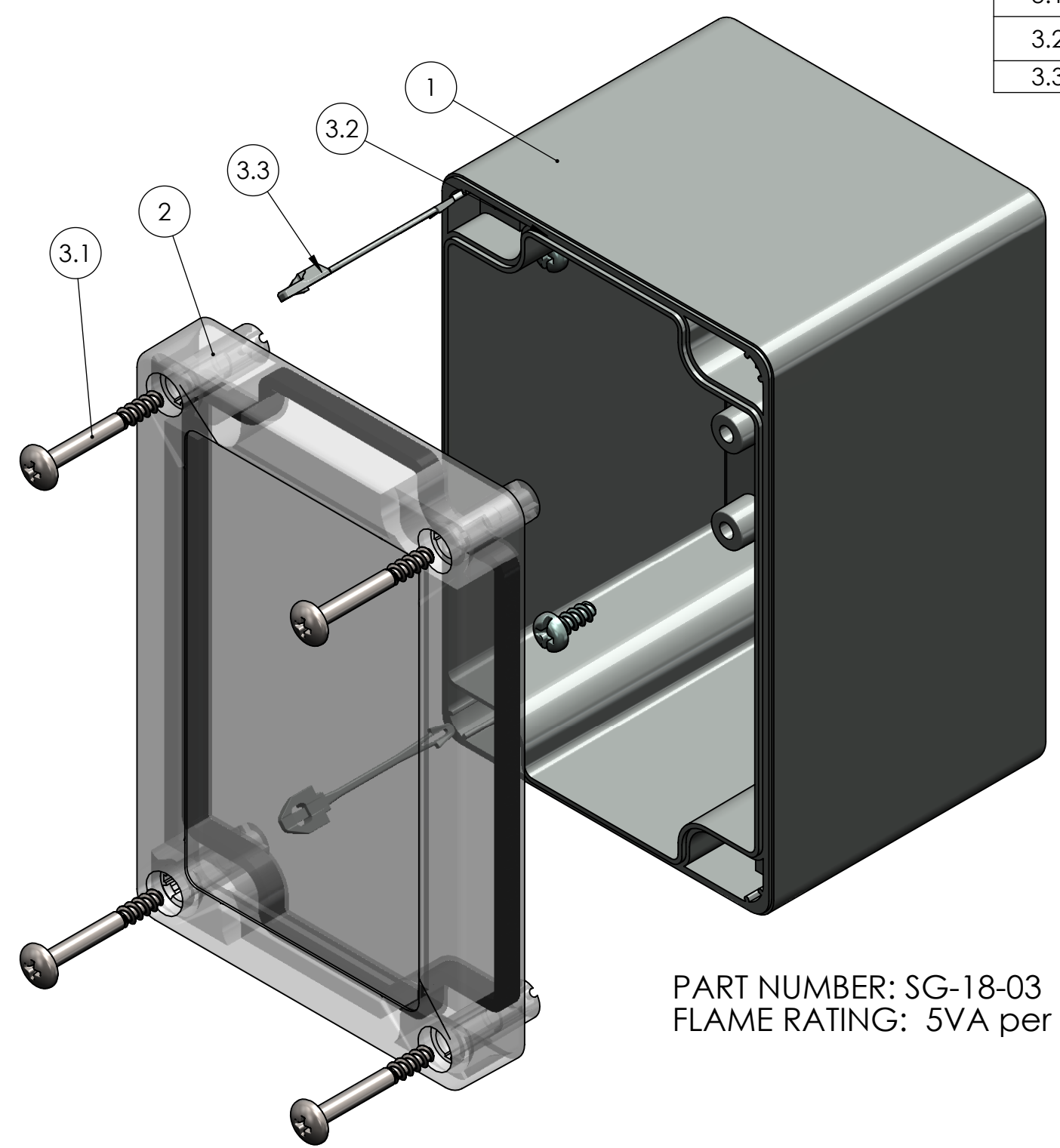

PART NUMBER: SG-18-03
 FLAME RATING: 5VA per UL50/UL746C

D
C
B
A

D
C
B
A

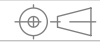
UNLESS OTHERWISE SPECIFIED: DIMENSIONS ARE IN: INCHES[mm] TOLERANCES: ANGULAR: ±2° TWO PLACE DECIMAL: ± THREE PLACE DECIMAL: ± PRINTED GRAPHICS: ±.010 PROPRIETARY AND CONFIDENTIAL THE INFORMATION CONTAINED IN THIS DRAWING IS THE SOLE PROPERTY OF POLYCASE. ANY REPRODUCTION IN PART OR AS A WHOLE WITHOUT THE WRITTEN PERMISSION OF POLYCASE IS PROHIBITED. CAD FILE: SG-18	PART NO. SEE BOM		 <small>1305 CHESTER IND. PARKWAY AVON, OHIO 44011-1083 U.S.A. PH#: 1-800-248-1233, 440-934-0444 FAX#: 440-934-0088</small>		
	MATERIAL				
	FLAME RATING	SIZE B	REV -	SCALE: 1:1  SHEET 2 OF 2	
	DRAWN CHECKED	NAME D.M.F.	DATE 10/9/2017 9/8/2015		

8 7 6 5 4 3 2 1

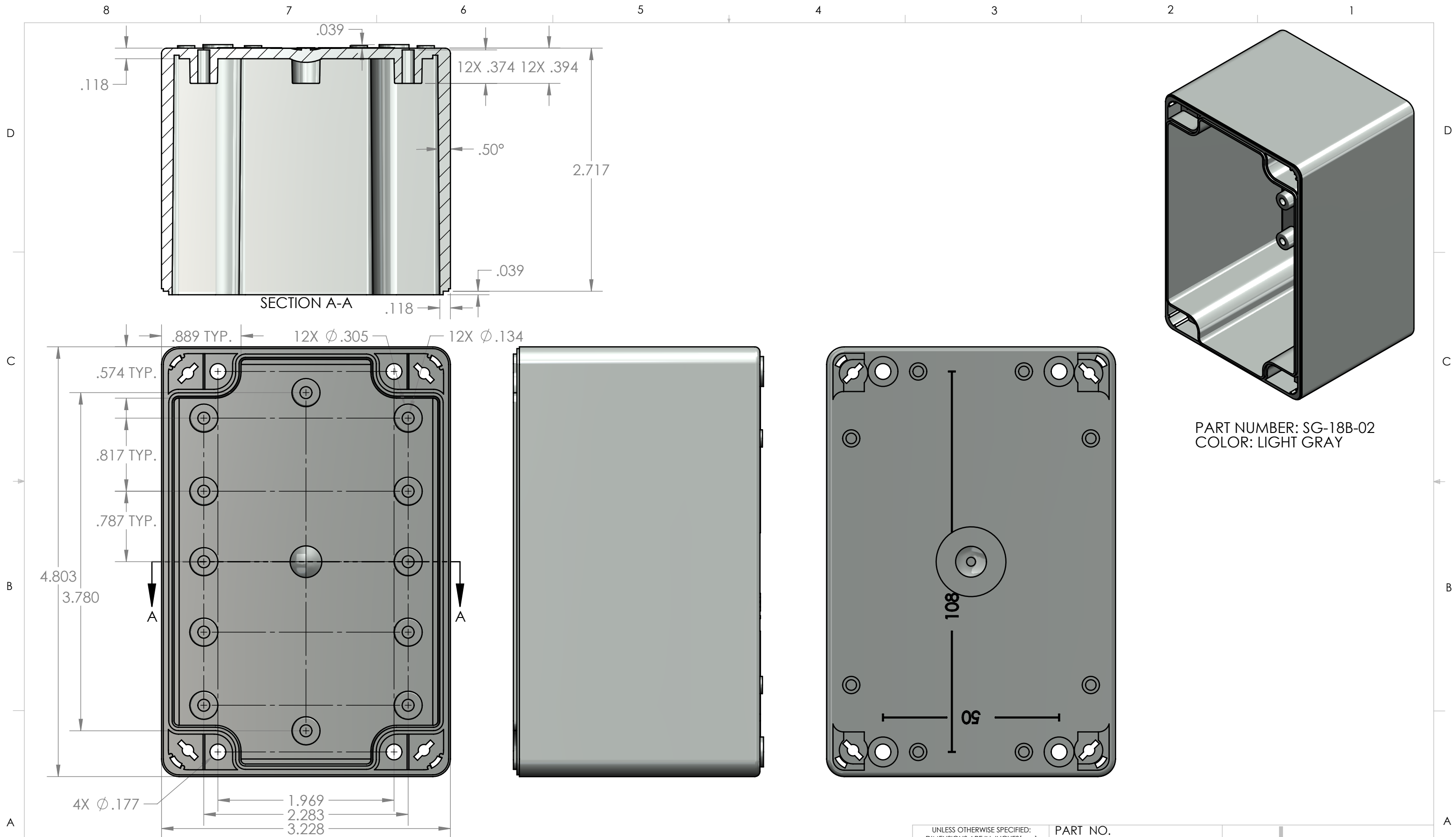

UNLESS OTHERWISE SPECIFIED: DIMENSIONS ARE IN: INCHES[mm] TOLERANCES: ANGULAR: ±2° TWO PLACE DECIMAL: ± THREE PLACE DECIMAL: ± PRINTED GRAPHICS: ±.010		PART NO. SG-18B-02		 <small>1305 CHESTER IND. PARKWAY AVON, OHIO 44011-1083 U.S.A. PH#: 1-800-248-1233, 440-934-0444 FAX#: 440-934-0088</small>	
PROPRIETARY AND CONFIDENTIAL THE INFORMATION CONTAINED IN THIS DRAWING IS THE SOLE PROPERTY OF POLYCASE. ANY REPRODUCTION IN PART OR AS A WHOLE WITHOUT THE WRITTEN PERMISSION OF POLYCASE IS PROHIBITED. CAD FILE: SG-18B		MATERIAL PC			
FLAME RATING		SIZE B	BASE		REV -
DRAWN	NAME	DATE	SCALE: 1:1		
CHECKED	D.M.F.	10/9/2017	SHEET 1 OF 1		
	-	9/2/2015			

REV.	DESCRIPTION	ZONE	BY	APPR'D	DATE
	REVISIONS				

8 7 6 5 4 3 2 1

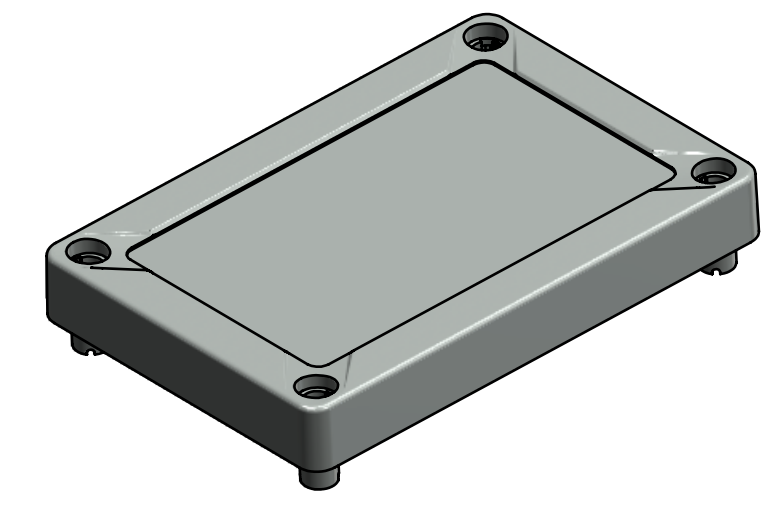
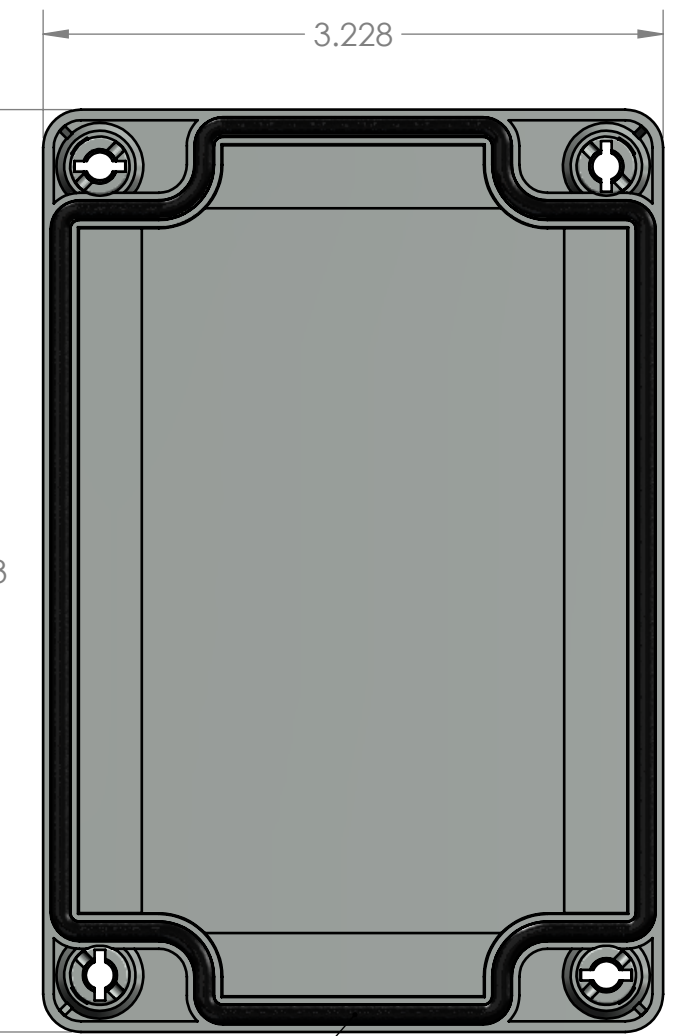
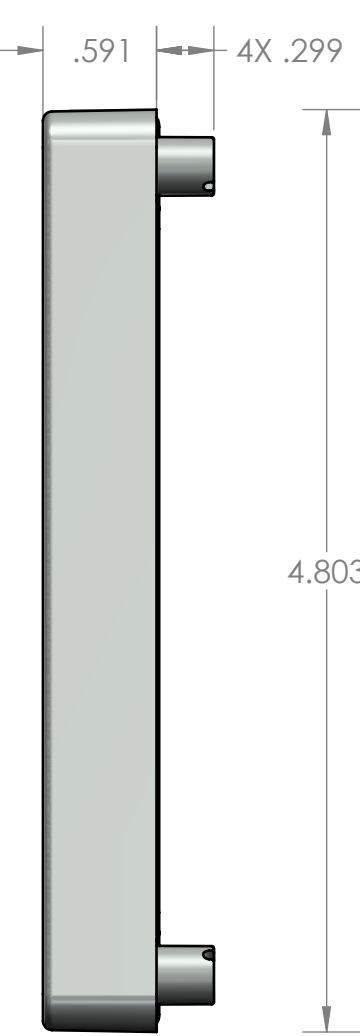
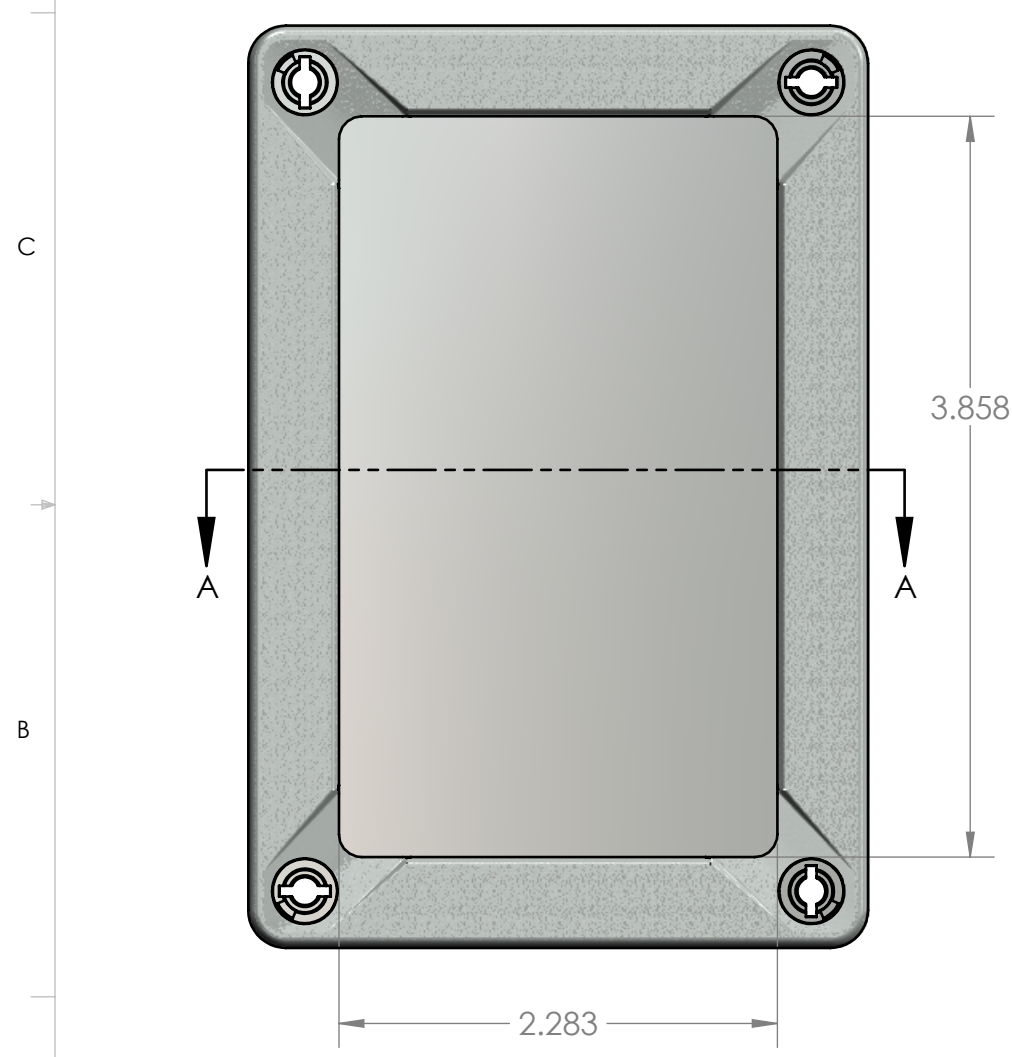
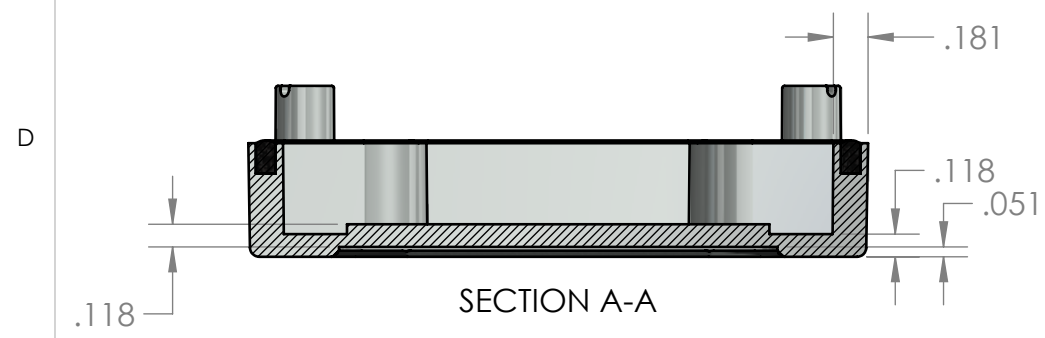

PART NUMBER: SG-11C-02
COLOR: LIGHT GRAY

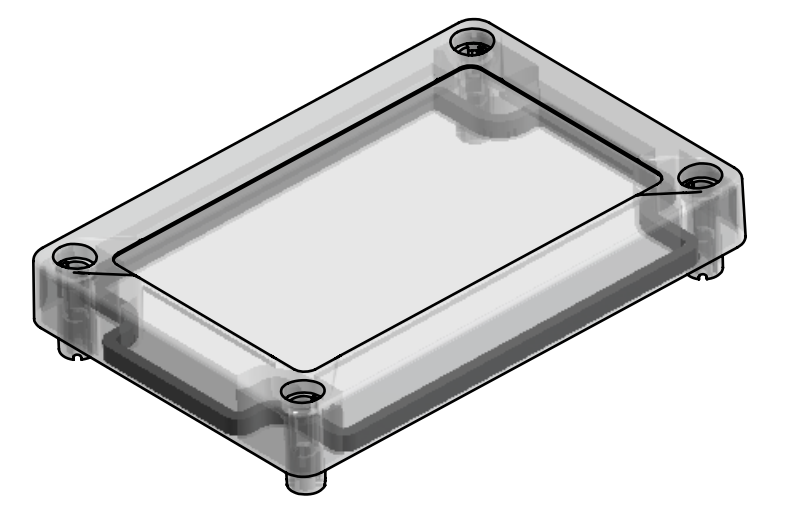

PART NUMBER: SG-11C-03
COLOR: CLEAR

UNLESS OTHERWISE SPECIFIED: DIMENSIONS ARE IN: INCHES[mm] TOLERANCES: ANGULAR: ±2° TWO PLACE DECIMAL: ± THREE PLACE DECIMAL: ± PRINTED GRAPHICS: ±	PART NO. SG-11C		 <small>1305 CHESTER IND. PARKWAY AVON, OHIO 44011-1083 U.S.A. PH#: 1-800-248-1233, 440-934-0444 FAX#: 440-934-0088</small>											
	MATERIAL PC													
	FLAME RATING -	SIZE B	REV -.01											
	PROPRIETARY AND CONFIDENTIAL THE INFORMATION CONTAINED IN THIS DRAWING IS THE SOLE PROPERTY OF POLYCASE. ANY REPRODUCTION IN PART OR AS A WHOLE WITHOUT THE WRITTEN PERMISSION OF POLYCASE IS PROHIBITED. CAD FILE: SG-11C	<table border="1"> <tr> <th>DRAWN</th> <th>NAME</th> <th>DATE</th> </tr> <tr> <td>D.M.F.</td> <td></td> <td>8/18/2015</td> </tr> <tr> <th>CHECKED</th> <th>NAME</th> <th>DATE</th> </tr> <tr> <td>B.M.B.</td> <td></td> <td>9/2/2015</td> </tr> </table>	DRAWN	NAME	DATE	D.M.F.		8/18/2015	CHECKED	NAME	DATE	B.M.B.		9/2/2015
DRAWN	NAME	DATE												
D.M.F.		8/18/2015												
CHECKED	NAME	DATE												
B.M.B.		9/2/2015												

8 7 6 5 4 3 2 1